

For more technical details / enquiries, please visit:

EUROPACE SERVICE CENTER

10 Changi South Street 3 #06-01 Singapore 486147

Tel: (65) 6457 3678 | Fax: (65) 6741 0728

Operating Hours: Monday - Friday: 9am - 5pm | Saturday: 9am - 12pm

Email: service@strategic.com.sg

www.europace.com.sg | www.strategic.com.sg

RELATED PRODUCTS & MAIN CONTACT HOTLINE

System Split Aircons | Tel: 6858 0801 | Email: systemac@strategic.com.sg (Twin City)

Portable & Casement Aircons | Tel: 6291 0800 | Email: portableac@strategic.com.sg (Jia Yue)

Refrigerators, Washing machines, Cookers & other major appliances |

Tel: 6289 0802 | Email: mda@strategic.com.sg (TnG)

Celebrate Fine Living!

This product is distributed by Strategic Marketing (S) Pte Ltd

If there is any technical amendment for the product, it will be edited on the updated version of the instruction manual without prior notice. The pictures shown in the instruction manual is only for illustration purpose only. If the appearance or colour of the product is modified, please refer to the actual appliance as a standard.

EuropAce®
TRUSTED SINCE 1992



AIR PURIFIER EPU 9800W

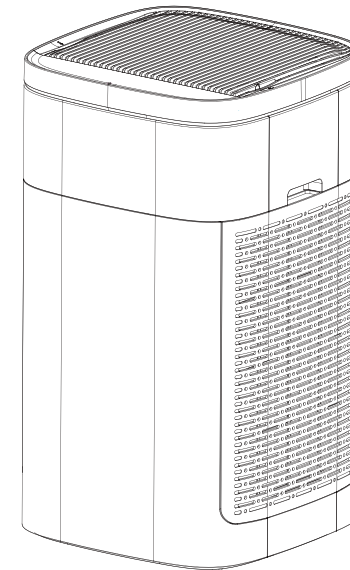

Celebrate Fine Living!

Thank you for purchasing EuropAce Products.
For safety purpose, please read this operating instruction manual carefully before using
and keep it for future reference.

Content

I. Performance index.....	01
II. Functions.....	01
III. Features.....	01
IV. Characteristics of filter screen.....	01
V. Product Structure.....	02
VI. Key & Display Panel.....	03
VII. Requirements on the placement.....	05
VIII. Installation of filter screen.....	05
IX. Methods of Use.....	06
X. Maintenance and Service.....	09
XI. Precautions.....	13
XII. Packing Details.....	13
XIII. Troubleshooting.....	14

I. Performance Index

Product name	Air purifier	Model	EPU 9800W
Use	To eliminate the pollutants such as particulate matters (PM), gaseous pollutants, microorganisms and the like in air.		
PM CADR	800m ³ /h	Mode of operation	Intelligent purification
PM CCM	P4	Rated voltage	220V-240V
Gaseous pollutant CADR	≥ 300m ³ /h	Rated frequency	50/60Hz
Gaseous pollutant CCM	F4	Rated power	85W
Noise	≤66dB(A)	Size (L×W×H)	40x40x66.9 cm
Applicable area	56 ~ 96m ²	Net weight	14.0Kg

II. Functions

- To purify gaseous pollutants such as smoke, dust particles and formaldehyde.
- To realize the sterilization and air purification of large-space houses, offices, restaurants, bars and entertainment places.

III. Features

- Air quality is shown by the four-color LED atmosphere light.
- Double filter screens generate clean air of double volume.
- The built-in high-precision particle sensor detects the air quality in real time.
- WiFi function, manual operation control, night sleep automatic control and infrared remote control.
- MANUAL, AUTO, TOPSPEED and NIGHT models.

IV. Characteristics of filter screen

1. Primary filter screen: To filter out large particles such as human hair, pet hair, cotton wool and other substances.

2. Copper ions and silver ions anti-virus PET skeleton composite filter

The latest research and development of copper ion and silver ion antibacterial antiviral technology, using PET skeleton as a carrier, carrying copper and silver ions, and then cooperate with medical H13 grade HEPA filter, so as to achieve the best effect of bacteria isolation, sterilization and antivirus. The third release test confirmed the obvious removal effect of SARS (SARS), H7N9 (avian influenza, coronavirus), H1N1 (respiratory influenza virus) and other viruses.

The H13 medical grade HEPA filtration accuracy is less than 0.3 microns, which can capture and reduce 99.97% of fine particulate matter in the air, such as pollen, pollutants, and allergens, and reduce the carrier of bacteria and viruses in the air.



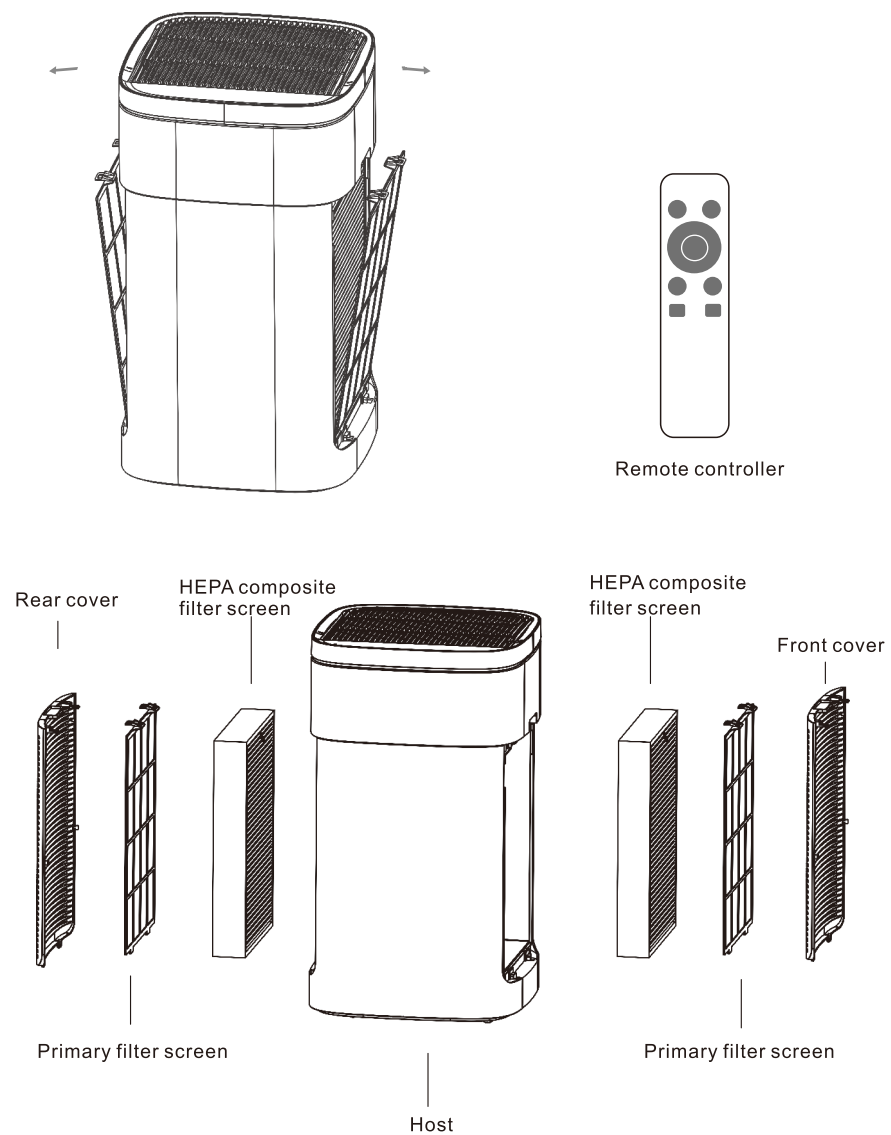







V. Product Structure



VI. Key & Display Panel





1. Switch key and function key

	Standby	Power on
Switch key	 Red	 Green
Function key		
Mode 	Air speed 	Child lock 
Timing 	Filter screen 	AUTO 
topspeed 	SLEEP 	

2.1 Replacement reminder for filter screen

The machine is designed with a reminder for regular replacement of the filter screen. When the machine has been operated for 300 hours, the red indicator flashes to indicate the need of cleaning the filter screen. When the machine has been running for 3,000 hours, the red indicator on the panel will be on normally to indicate the need of replacing the filter screen. At this time, the reset function of the key comes into effect. Keep pressing the key to reset the timing and re-start the timing.

	Normal	Due
Primary filter screen	No display	 The flashing red indicator, indicates the cleaning of the filter screen.
HEPA composite filter screen	No display	 The normally-on red indicator, indicates the replacement of the filter screen.



2.2 PM value correspondence table

PM2.5 concentration ug/m ³	1-35	36-75	76-150	151-500
Air quality	(Blue) Good	(Green) Fair	(Orange) Bad	(Red) Dirty

VII. Requirements for the placement

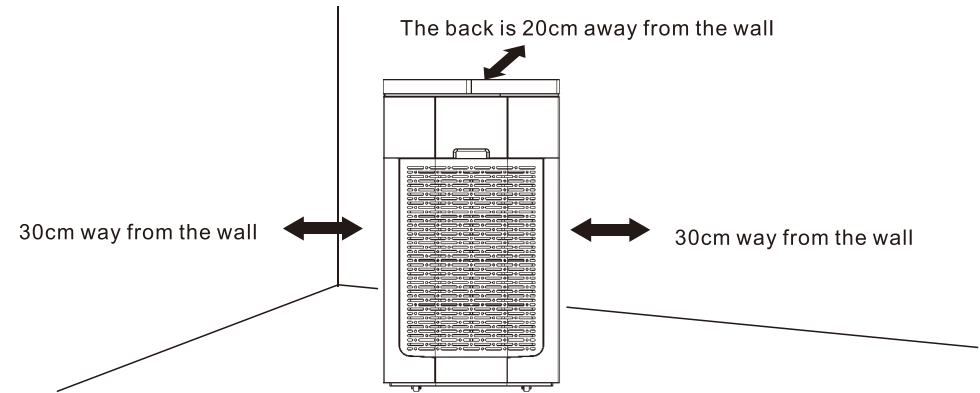

In the operation, the back of purifier should be kept 20cm away from the wall, and over 30cm on both sides.

VIII. Installation of filter screen

1. Take out the filter screen from the plastic bag

a. Remove the front and rear covers

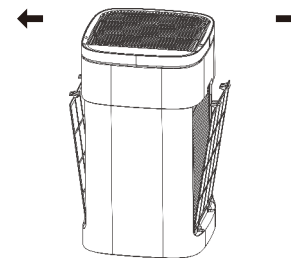

b. Remove the filter screen

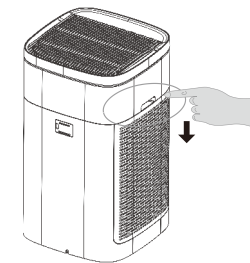

c. Take out the filter screen from the plastic bag



※ Before use, be sure to remove the plastic bag on the filter screen.

2. Install the filter screen and the front and rear covers

a. Install the HEPA composite screen

Note: One side of the strap is installed outward

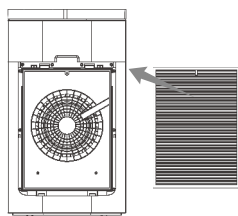

b. Install the primary filter screen

(with internal and external differentiation)

Note: The side with buckle is installed outward

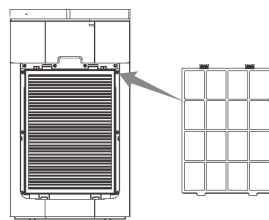

c. Install the front and rear covers

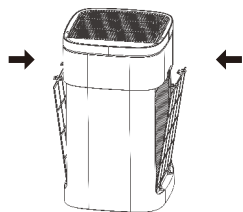



※ Before use, be sure to install the front and rear covers

IX. Methods of Use

1. Power it on

For first use, firstly take out the product from the packaging box, remove the binding wire of power cord, and then insert the plug into the power socket. When energized, the power key icon on the product panel will display red (🔴).





Gently touch  the machine to turn it on. Then the POWER key changes to green , and the machine enters the AUTO mode by default. At the same time, the front panel of the machine displays: AUTO (automatic mode).

2.  **Mode selection:** In the startup state, press the MODE key to select the mode: AUTO , TOPSPEED  and SLEEP . When the AUTO light is on, the anion is turned on, and the gear of the motor is changed upon receiving the data of the sensor. (The icon of the key is on when the AUTO function is on, and the icon is half-lit when it is turned off).

When the TOPSPEED light is on, the machine enters the TOPSPEED model.

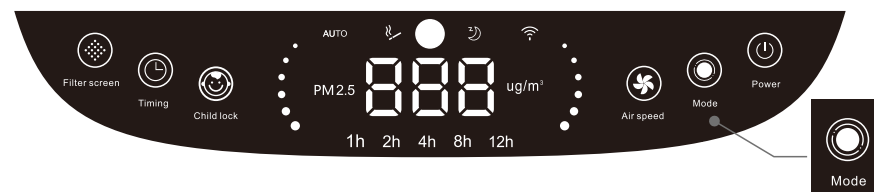
When the SLEEP light is on, the SLEEP function is turned on, and only the SLEEP light is half-lit. The machine can only work in the SLEEP mode and is not controlled by the sensor.



3.  **Manual:** In the startup state, touch the AIR SPEED key to switch the gear of the motor and adjust the operating speed of the machine. The motor is not controlled by the sensor after the man-made modification of the motor gear, and the motor can only work on the currently set gear.



4.  **Child lock:** In the startup state, press the CHILD LOCK key to enter the key locking state. At this time, all the keys are in the state of being unable to be touched or controlled, but the machine works in the pre-locked setting state. And then press the Child Lock for 5 seconds to release this state. (The icon of the key is on when the child lock function is activated, and half-lit when released.)



5.  **Timing:** Press this key to set timing shutdown in the startup state. Touch the TIMING key, and then the timing function will be added for 1 hour every time. After pressed for 12 hours, press it again for release the timing function. The timing shall be set in the range of 1-12 hours. (The icon of the key is on when the timing shutdown function is activated, and the icon is half-lit when deactivated.)

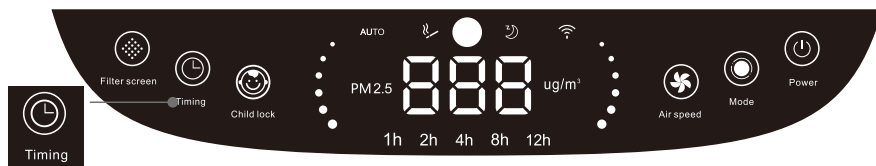

X. Maintenance and Service

1.Primary filter screen: The cleaning frequency of the primary filter screen should be determined according to the air speed, air pollution degree and cumulative operation time of product operation. It should normally be cleaned once normally for 2-3 months. Please clean it in time, otherwise the purification efficiency of the air purifier will be affected.

2. Copper ions and silver ions anti-virus PET skeleton composite filter

The latest research and development of copper ion and silver ion antibacterial antiviral technology, using PET skeleton as a carrier, carrying copper and silver ions, and then cooperate with medical H13 grade HEPA filter, so as to achieve the best effect of bacteria isolation, sterilization and antivirus. The third release test confirmed the obvious removal effect of SARS (SARS), H7N9 (avian influenza, coronavirus), H1N1 (respiratory influenza virus) and other viruses. The H13 medical grade HEPA filtration accuracy is less than 0.3 microns, which can capture and reduce 99.97% of fine particulate matter in the air, such as pollen, pollutants, and allergens, and reduce the carrier of bacteria and viruses in the air.

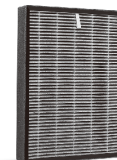

3.Cleaning of primary filter screen:

- 1) Turn off the power supply and pull the power plug off the socket.
- 2) Place the hand in the position of the handle and open it at a certain angle outwards. At this time, lift the back cover up to a certain distance and take down it from the product.

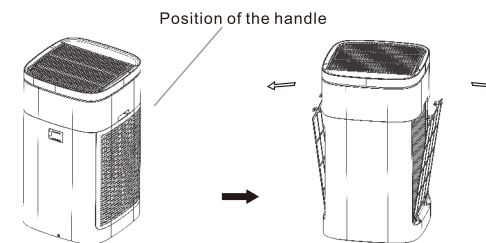

- 3) Grasp the two straps on the primary filter screen and pull out them gently, and then pull the primary filter screen upwards. Take care to avoid flying dust.

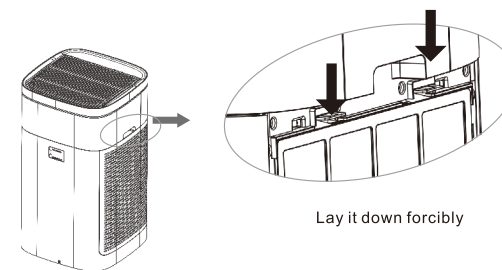

4) Cleaning methods: Clean the dust and floc with vacuum cleaner or brush. If the filter screen is very dirty, it can also be cleaned with water, and then dried completely, and then installed back to the purifier. (It cannot be bent in the cleaning so as to avoid damage)

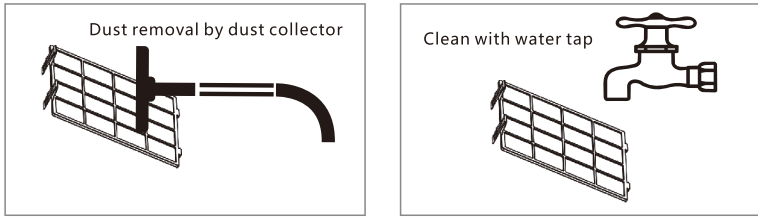

5) Installation methods: Insert the insertion piece below the filter screen into the corresponding card slot (pay attention to the direction of the filter screen. The two straps should be outward), and then buckle up the upper buckle.

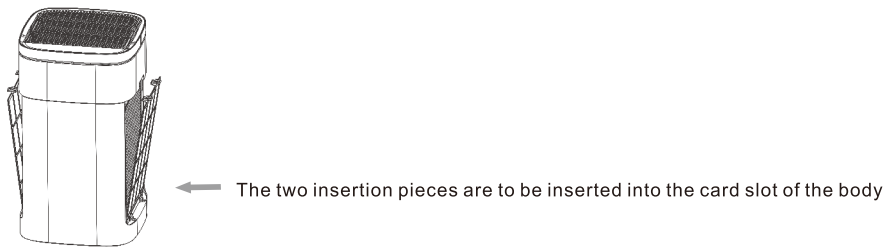

6) Install the filter assembly back to the product: Place the HEPA composite filter screen, the primary filter screen and the front cover respectively in the corresponding clamping positions of the machine, insert the insertion pieces into the corresponding clamping grooves, and then make the front cover engaged with the slot of the machine body.

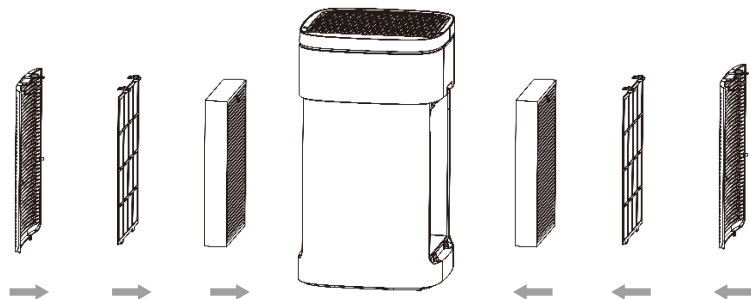

4. Intelligent reminder for filter screen replacement:

- 1) Turn off the power supply and pull the power plug off the socket.
- 2) Open the rear cover and take down the primary filter screen according to the same method specified in "Cleaning of primary filter screen".
- 3) Take out the HEPA composite filter screen to be replaced from the frame of the machine according to the replacement indication of the display panel, and then put the new filter screen into the filter screen frame in sequence, and lastly install the filter assembly back on the machine.

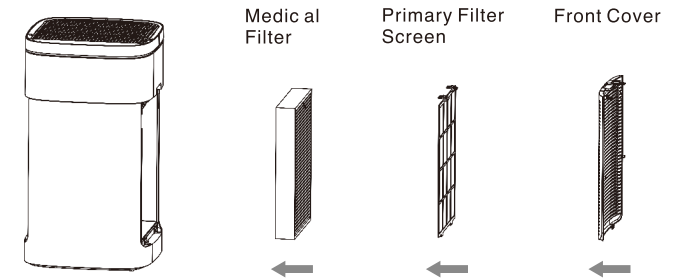

4) Turn on the power supply. In startup state, when the red light is normally on, press the FILTER SCREEN key for 5 seconds for resetting and new timing. In the normal startup state, press the FILTER SCREEN key, and then the accumulated working time (in hour) of the filter screen will be displayed on the display. Since there are only three digital displays, the display screen first displays a thousand-digit value, and then hundred-digit, ten-digit and single-digit values. Please read with the four values together. (The following figure shows the display mode of 2802 hours)

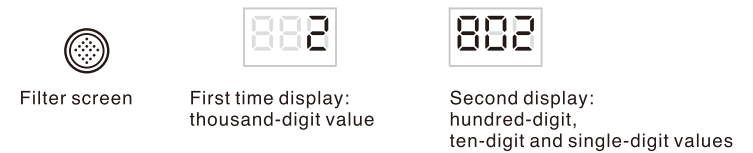

5) Pull off the power supply and install the rear cover on the product body.

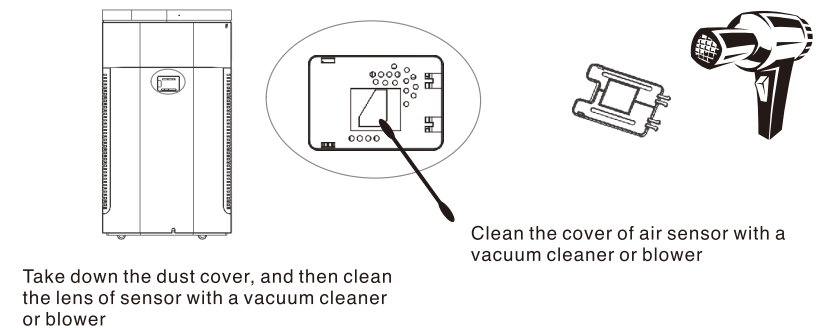

5. Cleaning of the machine:

Cleaning of the host surface:

Clean the dirt with a dry wipe,

Do not wash the machine with water.



Cleaning of air outlet:

1. Cut off the power and pull the plug off the power socket.
2. Place the hand on the side of air outlet grille with ▲, and turn it up and take it off.
3. Take out the air outlet grille when the machine is in operation, and then the machine stops running. Install it back to the machine, and then the machine continues with the operation before the power-off.

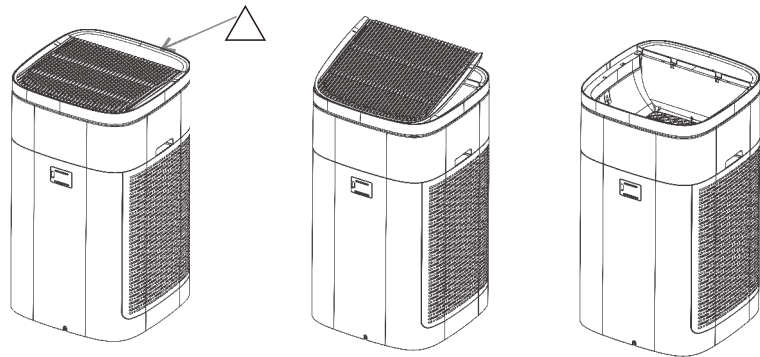

6. Maintenance and cleaning of anion generator:

When the machine sounds “creak”, the anion generator needs to be cleaned. Take out the air outlet grille, and stir and clean the dust on the anion emitter with cotton swab from the iron net over the emitter. This cleaning should be carried out on a regular basis.

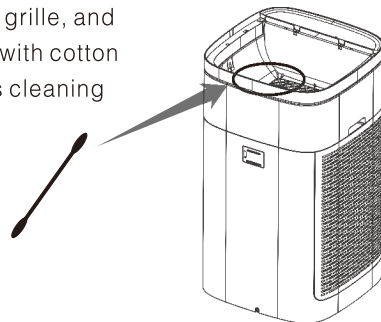







XI. Precautions

Safety precautions

When humidity in the room is very high, the air quality sensor may form condensed water. In this case, in the AUTO mode, even if the air quality is good, the status light on the panel will show poor air quality. It is recommended that you manually select the air volume.

Warning

 No wet hands!	Do not contact the power plug with a wet hand.	 Pull out the plug!	Make sure to disconnect the power supply before cleaning the machine.
 No!	Do not use other forms of power. Only AC220V50HZ can be used as power source. The user must not open the case for maintenance. The maintenance must be operated by professional maintenance personnel. Do not pour water or liquid or flammable cleaning agent into the product so as not to cause damage to the product or cause fire due to electric shock.		In the operation, the back of purifier should be kept 20cm away from the wall, and over 30cm on both sides. Place the product in a dry and smooth horizontal plane and keep it away from heat source and too wet location.
 No!	Do not clean the body with solvents or chemical liquids in order to avoid corrosion of the body. Do not place the hand or any object into the air outlet. Do not pull the power cord from the power supply. The plug should be removed safely by holding the power socket. Do not place any articles at the air inlet and outlet, so as not to affect the flow of the air and reduce the purification efficiency.		Remove the power plug when the machine will not be in use for a long time. Pay attention to child who should not come into contact with and use the purifier. Keep the smooth air flow in the air inlet. Do not let dust, lint, hair or other substances block the air inlet.

XII. Packing Details

Body	1 PCS
Primary filter screen	2 PCS
HEPA composite filter screen	2 PCS
User Manual	1 PCS
Remote controller	1 PCS

XIII. Troubleshooting

Common Faults	Check/Solutions
The machine can't start up (the power light does not light in red)	1. Is the power cord plug inserted properly? →Plug in the power cord plug. 2. Are the left and right air inlet plates of the purifier well covered? →Cover the left and right air inlet plates of the purifier.
The machine can't start up (the power light is flashing). There is no response when pressing the key.	Is the top air outlet grille properly installed? Note that the direction of the air outlet grille should be correct . →Install the top air outlet grille in place.
The air is polluted, but the air pollution indicator is still green	Is the purifier placed in a place where dirty air (dust) is not available? →Change to a new place.
The air pollution indicator is always "Red", even if it is running continuously.	Is the particle sensor dirty? →Clean the particle sensor.
The sound of [snap] and [clank] in operation.	Is the generator too dusty? →Clean the anion generator.
The smell of the air outlet makes people feel uncomfortable.	1. Is the filter screen dirty? →Clean the filter screen. 2. Has the filter screen not been replaced for a long time? →Replace with a new filter screen.
The machine can't enter the SLEEP mode at night.	Is the purifier operating in MANUAL mode? →Press the "MODE" key on the operation panel and ensure that the purifier is operating in AUTO mode.
The operation time of the purifier is very long, but the air quality is not obviously improved.	1. Is the plastic bag on the purifier filter screen removed? → Please remove the plastic bag on the filter screen before the first use. 2. Is the order of the purifier filter screen incorrect? →See the instructions for installation sequence and precautions.
The alarm light for filter screen is flashing	It indicates that the timing of the primary filter screen has reached the set value. After the filter screen is cleaned, keep pressing the FILTER SCREEN key for resetting.
The alarm light for filter screen is normally on	It indicates that the timing of the HEPA composite filter screen has reached the set value. After the filter screen is cleaned, keep pressing the FILTER SCREEN key for resetting.

目录

一. 性能指标.....	01
二. 产品功能.....	01
三. 产品特点.....	01
四. 滤网特性.....	01
五. 产品结构.....	02
六. 按键显示面板.....	03
七. 产品摆放要求.....	05
八. 安装过滤网.....	05
九. 使用方法.....	06
十. 维护与保养.....	09
十一. 注意事项.....	13
十二. 装箱明细.....	13

一. 性能指标

产品名称	空气净化器	产品型号	EPU 9800W
用途	去除空气中的颗粒物、气体污染物、微生物等污染物。		
颗粒物CADR	800m ³ /h	工作方式	智能净化
CCM颗粒物	P4	负离子产生浓度	1千万/cm ³
颗粒物净化能效m ³ (W/h)	高效级	额定电压/频率	AC 230V/50Hz
CADR甲醛	≥300m ³ /h	额定功率	85W
CCM甲醛	F4	待机功率	≤2W
甲醛净化能效m ³ (W/h)	高效级	电源线长度	2 米
噪声	≤66dB(A)	产品尺寸(长宽高)	40x40x66.9cm
适用面积	56 ~ 96m ²	净重	14.0Kg

二. 产品功能

- 净化烟雾、尘埃颗粒和甲醛等气态污染物。
- 可激发大量负离子以改善空气质量，优化生活环境。
- 可实现大空间家庭、办公室、饭店、酒吧和娱乐场所的杀菌及空气净化。

三. 产品特点

- 四色LED氛围灯显示空气质量。
- 双套滤网过滤，双倍输出洁净空气。
- 内置高精度颗粒物传感器实时检测空气质量。
- WiFi功能、手动操作控制、夜间睡眠自动控制和红外遥控控制。
- 手动、自动、极速、夜间四种净化

四. 滤网特性

- 1、初效滤网：可滤除较大的颗粒，如人体头发、宠物毛发、棉絮状等物质。
- 2、HEPA复合滤网：可滤除烟雾、灰尘、花粉、过敏源，污染物以及大于0.3微米的细微颗粒，可滤除有害气体、如苯、甲醛、恶臭等气味。



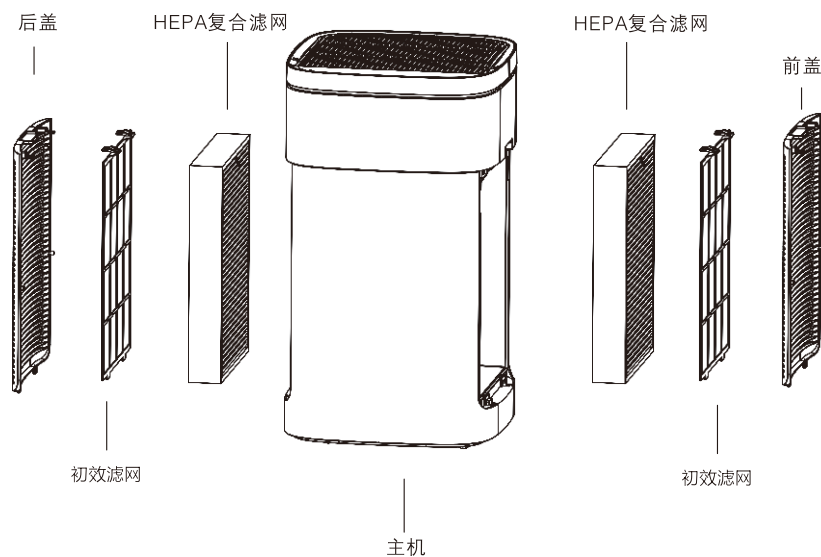
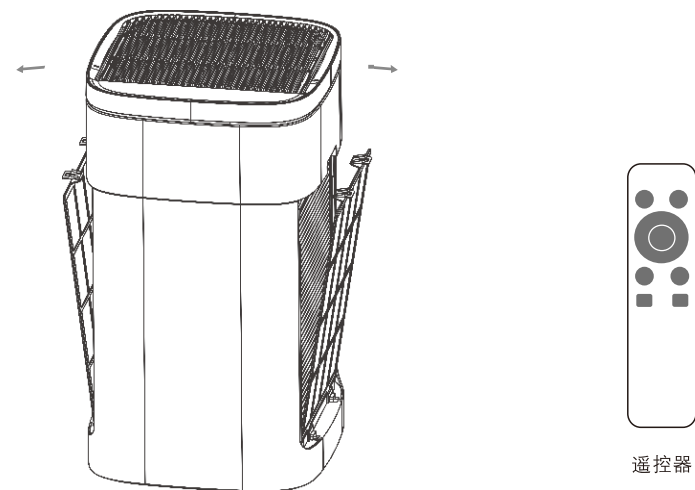







五. 产品结构



六. 按键显示面板





1. 开关按键和功能按键显示

	产品待机	产品开机
开关按键	 红色	 绿色
功能按键		
模式 	风速 	童锁 
定时 	滤网 	自动 
极速 	睡眠 	

2.1 滤网更换提醒

本机器带有滤网定时更换提醒功能，当机器运行300小时后，红灯闪烁提示清洁滤网，当机器运行到3000小时后，面板上的红灯指示灯会常亮起，提示用户更换滤网。此时按键的复位功能生效，触摸此按键可以复位定时并重新开启计时。

	正常	到期
初效过滤网	无显示	 闪亮红色灯 提示清洁滤网
HEPA复合滤网	无显示	 常亮红色灯 提示更换滤网



2.2 PM数值对应表

PM2.5浓度ug/m ³	1-35	36-75	76-150	151-500
空气质量	(蓝)良好	(绿)一般	(橙)偏差	(红)污浊

七. 产品摆放要求

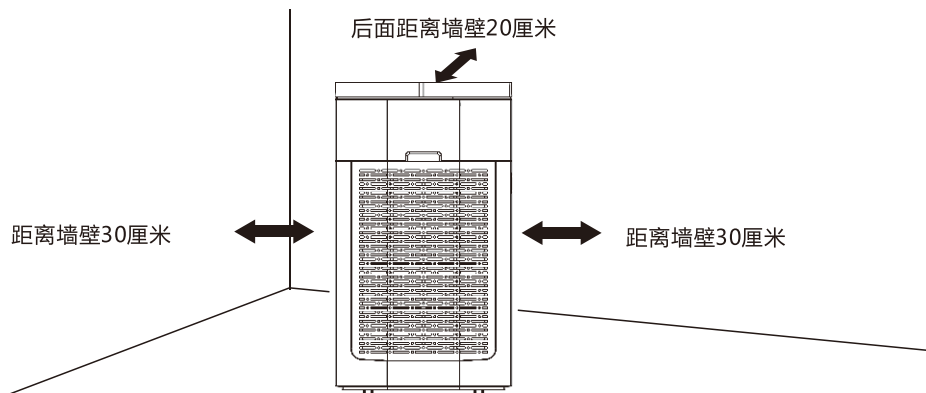

净化器在工作时，应保持背后留20厘米，两侧保持30厘米以上的空间。

八. 安装过滤网

1. 从塑料袋中取出滤网

a. 撤下前后盖

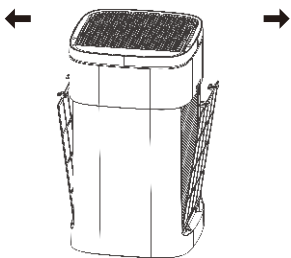

c. 从塑料袋中取出过滤网

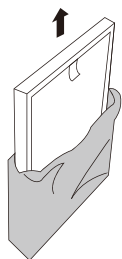

b. 撤下过滤网

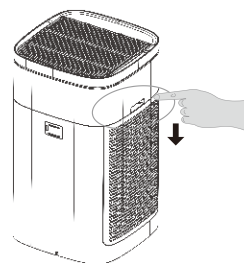

※使用前，请务必去除滤网上的塑料袋

2. 安装过滤网和前后盖

a. 安装HEPA复合滤网

注意：带拉片一面向外

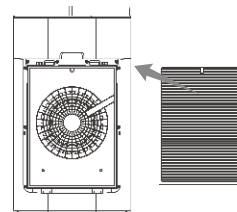

c. 安装前后盖

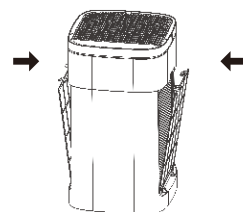

b. 安装初效滤网（有内外区分）

注意：带扣手一面向外

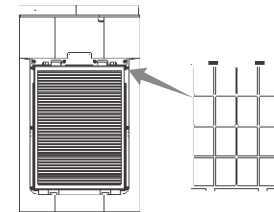

※使用前，请务必安装前后盖

九. 使用方法

1. 接通电源

首次使用产品，先将产品从包装盒中取出，去掉电源线绑线，将插头插到供电插座上。通电后，产品面板电源按键图标显示红色。



轻触 机器正式开启，电源按键变绿灯 ，机器会默认进入自动模式。同时机器前面板上显示：AUTO（自动模式）。

2. **模式选择**：开机状态下，按模式键可以选择自动模式 **AUTO**、极速净烟模式、睡眠模式。当自动灯亮时，负离子开启，电机的档位受到传感器的数据进行更换档位。（自动运行功能开启时按键的图标点亮，关闭时图标半亮）。当极速净烟灯亮时，极速指示灯亮后即进入极速净化模式运行。当睡眠灯亮时，睡眠功能开启后，机器的灯光亮度减半提示。机器只能在睡眠档工作，不受传感器的控制。



3. **手动模式**：开机状态下，触摸风速键切换电机的档位，调节机器的运行速度。人为的修改电机档位后电机不受传感器的控制，电机只能工作在当前设定的档位上。



4. **童锁**：开机状态下，按儿童锁按键进入按键锁定状态，此时所有的按键都处于不能触摸控制的状态，但机器照样工作在锁定前的设定状态下。再按儿童锁5秒钟锁定状态解除。（童锁功能开启时按键的图标点亮，解除童锁功能时图标半亮。）



5. **定时**：开机状态下按此键设定为定时关机。触摸定时按键，定时功能每按一下加1小时，按到12小时后，再按则关闭定时功能，定时时间设置范围1-12小时。（定时关机功能开启时按键的图标点亮，关闭时图标半亮。）

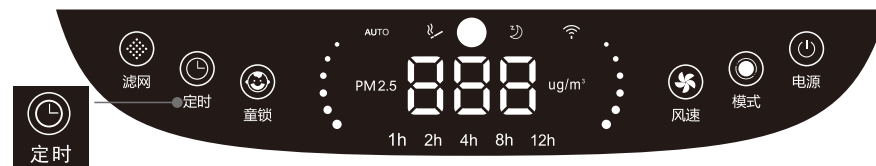

十. 维护与保养

1. 初效滤网：初效滤网的清洗频率需根据产品运行的风速，空气污染程度，及累计运行时间而定，一般正常使用2~3个月应清洗一次。请及时清洗，否则会影响空气净化器的净化效能。

2. HEPA复合滤网：由HEPA、吸附净化材料、催化净化材料、功能性过滤材料组成的多功能复合过滤器，能有效净化空气中的悬浮颗粒物、病毒、细菌并有效去除异味及有害气体。



3. 初效滤网的清洗：

- 1)关闭电源，将电源插头从插座上拔下。
- 2)将手放置在提手位置，向外拉开一定角度，此时需将后盖向上提拉一定距离，方可从产品上取下。

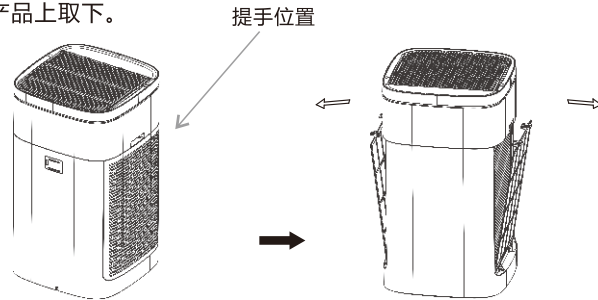

- 3)抓住初效滤网上的两个拉片，轻轻向外拉出，再把初效滤网向上拉脱，小心注意灰尘造成飞扬。

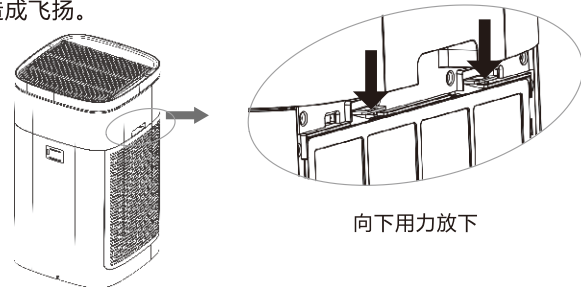

- 4)清洁方法，可用吸尘器或毛刷清除灰尘和絮状物，如果滤网很脏，也可以用水洗洁精清洗，完全晾干后，再安装回到净化器上。（清洁过程不折弯，以免损坏）

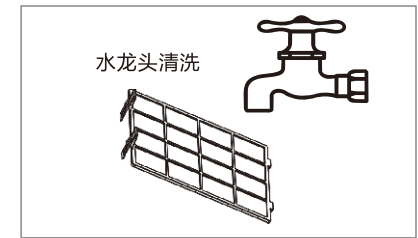
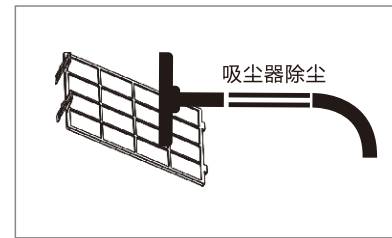

- 5)安装方法，将滤网下方的插片插到相应的卡槽内（注意滤网的方向，两个拉片朝外），然后将上方的扣位扣上即可。

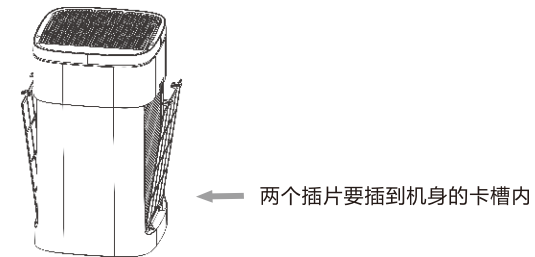

- 6)将过滤器组件装回到产品上，先将HEPA复合滤网、初效滤网、前盖分别放到机器相应的卡位位置，把插片插到相应的卡槽内，然后将前盖与机身的卡槽吸合。

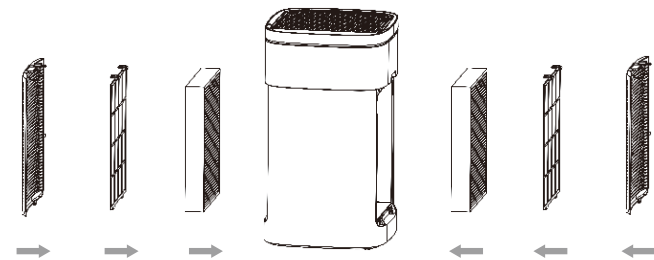

4.智能提醒滤网更换：

- 1)关闭电源，将电源插头从插座上拔下。
- 2)用“初效滤网的清洗”同样的方法打开后盖取下初效滤网。
- 3)根据显示面板更换提示，把要更换的HEPA复合滤网从机器的框内取出，再将新的滤网按照顺序放入滤网框内，然后将过滤器组件装回到机器上。

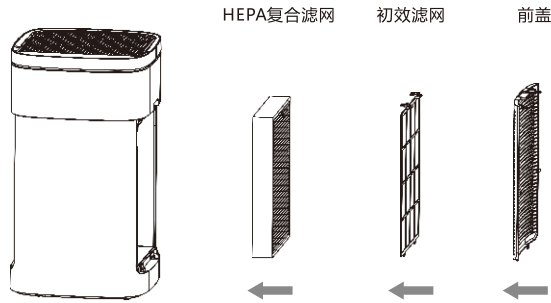

- 4) 接通电源，在开机状态，当红灯常亮长按滤网键5秒进行复位并重新计时。平时开机状态下，按一下滤网键，屏幕上显示滤网的累计工作时间，单位为小时。由于只有三个数显，所以显示屏首先显示千位数，再显示百位到个位的数值，请把四个数据连起来一起看。(如下图为2802小时的显示方式)



- 5) 最后拔掉电源，将后盖安装到产品机身上。

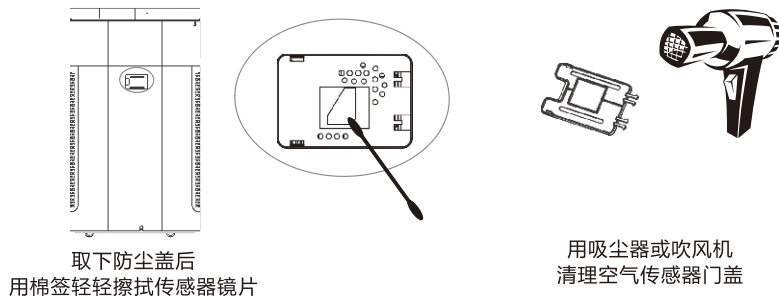

5.机器的清洁：

- 主机表面的清洁：
- 用干抹布擦去污渍，
切勿用水冲洗机器。



出风口清洁：

- 1.关闭电源，将插头从插座上拔下。
- 2.将手放在出风格栅有▲符号一边，往上翻起拿掉。
- 3.运行时取出出风格栅，机器停止运行，出风格栅放回去继续执行断电前功能运行。

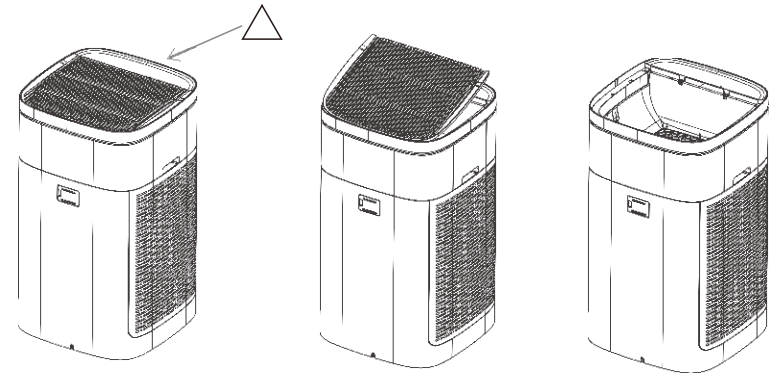

6.负离子发生器保养清洁：

- 当听到机器发出“吱吱”的声音时，需要清洁负离子发生器。取出出风格栅，使用棉签作为清洁工具，从出风口负离子发射头上方铁网进入，左右拨动清洁负离子发射头上的灰尘。此项清洁应定期进行。

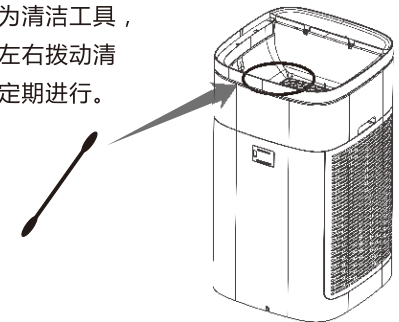

十一. 注意事项

安全注意事项

当室内的湿度非常高，空气质量传感器上可能会形成冷凝水，此时，在自动模式下，即使空气质量很好，面板上的状态灯也会显示空气质量较差，建议您手动选择风量。



	切勿使用湿手接触电源插头。		在清洗机器前，务必确保断开电源。
禁止湿手！		拔去插头！	
	切勿使用其他形式的电源，只可使用AC 220V 50Hz为产品供电。用户切勿自行打开外壳进行维修，维修必须由专业维修人员操作。切勿将水或液体或易燃清洗剂倒入产品内，以免造成产品损坏或引起电击造成火灾。		净化器在工作时，应保持背后留20cm，两侧保持30cm以上的空间。请将本产品放置在干燥、平稳的水平面使用，并远离热源和过于潮湿的位置。
禁止！			
	切勿使用溶剂和化学液体对机身进行清洗，以免腐蚀机身。切勿将手或任何物体放入出风口内。切勿拉扯电源线断开电源，应抓住插头安全拔除电源线插头。切勿在进风口出风口放置物品，以免影响气体的流动，降低净化效率。		长期不使用时应拔掉电源插头。监督儿童不要接触和使用本净化器。要保持进风口空气气流的通畅，不要让灰尘，棉絮，毛发或其他物质阻碍进风口。
禁止！			

十二. 装箱明细

机体	1个
初效滤网	2张
HEPA复合滤网	2张
产品说明书	1本
遥控器	1个

故障排除

常见故障现象	检查/解决方法
不能开机（电源灯没亮红灯）	1.电源线插头是否插好？ →插好电源线插头。 2.净化器左右进风板是否盖好？ →盖上净化器左右进风板。
不能开机（电源灯闪亮） 按按键无反应	顶部出风栅格网是否安装好？ 注意出风栅格网方向要正确 →把顶部出风栅格装到位。
空气有污蚀，但空气污染度 指示灯仍亮“绿色”	是否将净化器放在了不容易吸到 污蚀空气（灰尘）的地方？ →改变一下放置位置。
即使是持续运行， 空气污染指示灯 一直为“红色”。	确定颗粒感应器是否脏污？ →清洁颗粒感应器。
运转中，[啪啪]、[唧]的声音	负离子发生器是否太多灰尘？ →清洁负离子发生器。
出风口的气味让人感觉不适	1.过滤网是否脏污？ →清洁滤网。 2.过滤网是否长期未更换？ →更换新的过滤网。
夜间不自动进入睡眠模式	净化器是否在手动模式下运行？ →在操作面板上按“模式键”按钮， 确保净化器在自动模式下运行。
净化器运行时间很长 但空气质量没有明显提高	1.净化器过滤网上的塑料袋是否去除？ →初次使用前请先去除过滤网上的塑料袋。 2.净化器过滤网的顺序是否装错？ →安装顺序及注意事项详见说明。
滤网报警灯闪烁亮	表示初效滤网定时计时已到设定值， 此时清洗滤网后长按滤网键进行复位即可。
滤网报警灯常亮	表示HEPA复合滤网定时计时已到设定值， 此时更换滤网后长按滤网键进行复位即可。

Product Warranty

The Warranty Card is not provided in the product packaging. You can register the product warranty online at our website <https://www.europace.com.sg/ewarranty/> within 7 (seven) days from the date of purchase. You will enjoy an additional 3 months of the product standard warranty when you register online. Please produce your E-warranty registration when requesting for repair and service at our Service Centres nearest to you.

In the event, if you are unable to register the product warranty online you must produce your purchase receipt/tax invoice and such other documentary proof of purchase of the appliance when requesting for repair and service.

Product Warranty Coverage

You may find out your product warranty coverage at the link below before calling our Customer Service Hotline (65) 6457 3678 or visiting our Service Centre.

http://europace.com.sg/ewarranty/src/cupload/settings_pdf/1/1-1-2c899-1563960978-WARRANTY-COVERAGE-19_0221.pdf

TERMS & CONDITIONS OF WARRANTY (THIS WARRANTY IS VALID IN SINGAPORE ONLY)

Your appliance is warranted against faulty design, workmanship or materials for a period of 12 months unless otherwise stated from the date of purchase, subject to the following terms & conditions herein below:-

- 1) That the owner shall register the product warranty online at our website www.europace.com.sg within 7 (seven) days from the date of purchase.
- 2) That the appliance shall be used solely for domestic purposes and not for commercial purposes or any other purposes whatsoever and used strictly under the instruction for operation as provided by the manufacturers or the appliance.
- 3) That if any time during the warranty period any part or parts of this appliance is removed, tampered, modified, adjusted, altered, handled or repaired in any way whatsoever by any persons other than those authorized by Strategic Marketing (S) Pte Ltd, this warranty shall immediately cease to be valid and become void.
- 4) That the owner shall produce the E-warranty registration or tax invoice/receipt and such other documentary proof of purchase of the appliance to our satisfaction as we may deem necessary when requesting for repair and service.
- 5) That our decision on all queries relating to complaints as to defects either of workmanship or of materials shall be conclusive and the owner shall agree to abide by such a decision. Any appliance or defective part which has been replaced shall become our property.
- 6) The terms and conditions of this warranty shall be contained exclusively in this document and no other presentation of provision, either written or otherwise, regardless of the origin of the same, shall be accepted as either adding or removing from these terms and conditions.
- 7) That this warranty shall cease to be valid and void if the appliance is exported or relocated from Singapore.
- 8) That there shall be no removal, alteration, defacement, or made illegible/tampered or any kind of the serial number on the appliance.
- 9) That the owner shall be fully responsible for the due delivery and collection of the appliance for any work done according to this warranty. Transportation expenses incurred for delivery or handling the appliance are chargeable to the owner.
- 10) Transportation and labour charges apply after the full parts warranty expires. Refer to <https://www.europace.com.sg/ewarranty/> for more information.

In addition to the above, this warranty shall be subjected to the following limitations and exclusions:-

a) The appliance shall be warranted by STRATEGIC MARKETING (S) PTE. LTD. from date of purchase only for a period of:-

10 years - Heating Element warranty applies to selected models of Storage Water Heaters.
- Tank Leakage warranty applies to selected models of Storage Water Heaters.

8 years - Motor warranty applies only to selected models of Stand Fans (Walk-in warranty).

10 years - Compressor warranty applies to selected models of Refrigerators.

6 years - Motor warranty applies only to selected models of Stand Fans (Walk-in warranty).
- Compressor warranty applies only to selected models of System Air Conditioners and Portable Air Conditioners.

5 years - Compressor warranty applies to Refrigerators, Freezers, Wine Coolers, Portable Air Conditioners & Casement Air Conditioners (Outdoor warranty). Transportation is chargeable from the 2nd year to 5th year.

- Compressor warranty applies to Dehumidifiers (Walk-in warranty)

- Motor warranty applies only to selected models of Stand Fans (Walk-in warranty).

3 years - Full parts warranty applies only to selected models of Air Purifiers & selected models of Dehumidifiers (Walk-in warranty).

- Heating Element warranty applies only to selected models of Garment Steamers (Walk-in warranty).

- Motor warranty applies only to selected models of Jet Turbine Fans & selected models of Air Coolers (Walk-in warranty).

2 years - Motor and internal parts warranty applies only to selected models of Stand Fans, selected models of Oscillation Power Fans & selected models of Air Purifiers (Walk-in warranty).

- Heating Element warranty applies to selected models of Electric Ovens & selected models of Kettle Jugs. (Walk-in warranty)

- Motor warranty applies only to selected models of Jet Turbine Fans (Walk-in warranty).

- Full parts warranty applies only to Wine Coolers of 34 Bottles & above.

1 year - Full parts warranty applies to *Lifestyle Products (cash & carry items), Small Kitchen Appliances, Fans, Air Coolers, Wine Coolers of 20 Bottles & below, Mini Bar Fridge (Walk-in warranty)

- Full parts warranty apply to Refrigerators, Air Conditioners & Freezers (Outdoor warranty).

Check out the warranty coverage of your appliance at www.europace.com.sg

b) The owner waives all or any claims to compensation monetary or otherwise which he/she may be entitled to and shall agree to accept any compensation whatsoever by way of additional repairs or otherwise which we in our absolute discretion may deem fit to offer. The giving of compensation shall be subjected to the other provisions of the warranty.

c) This warranty shall not be transferable, negotiable or assignable to any third party.

d) The warranty does not include transport delivery or handling charges incurred in the transportation of the appliance to and from Strategic Marketing (S) Pte Ltd.

e) Damage caused during transit where the appliance is transported for servicing, repair, or in relation thereof or connection therewith.

f) In respect of refrigerator and air conditioner only, upon the expiry of 12 months from the date of purchase, this warranty will not cover transport, refrigerant and labour to install a new compressor.

- g) This warranty will not cover chemical cleaning, maintenance service, general service and overhaul, which if confirm is chargeable.
- h) Defects or fault in the appliance which has been used for commercial purposes or which have been rented/leased or which have been otherwise subject to other than household use.
- i) Claims for damaged/missing parts after 3 days from the original date of goods received will not be valid.
- j) This warranty and the Replacement Scheme does not particularly cover damages and/or defects arising from
- Usage of wrong electrical supply/voltage.
 - Usage not according to the Instruction Manual provided by the manufacturers.
 - Misuse, accidents, negligence, abuse, improper installation, or any manner of tampering.
 - Normal wear and tear.
 - Corrosions rusting or stains.
 - Scratches, dents on the unit body, casing or paintwork of the appliance.
 - Act of God, fire, flood and civil unrest.
- We shall not under any obligation, legal or otherwise to repair this appliance or one to one exchange if the same shall be required as a result of losses, damages, and malfunctions arising from any of the causes mentioned in the paragraph.
- k) All accessories, external parts and extruded parts such as front panel, casing, door, glass cover, glass door, cable/cord assembly, batteries, adaptor, plug, remote control, control knob, buttons, filter, UV lamp, oven tray, wooden rack, exhaust hose, fixtures, panels, cover, lid and lever, plastic parts, fan blades, blade guard, inner pots, brushes, water tanks, attachments made of glass, plastic and/or porcelain, detachable parts, and other option items are excluded from this warranty.

All services provided after the warranty period will be chargeable at standard rates determined by STRATEGIC MARKETING (S) PTE. LTD.

The terms and conditions of this warranty shall be varied except with the written and express consent or agreement of Strategic Marketing (S) Pte. Ltd. While Strategic Marketing (S) Pte. Ltd. endeavours to repair any defects after the warranty period, it is subject to availability.

It is hereby expressly provided that any liability of Strategic Marketing (S) Pte. Ltd. for any loss or damage whatsoever arising from, relating to or in connection with the purchase of the appliance shall not exceed the purchase price (excluding installation costs) of the appliance. Similarly, Strategic Marketing (S) Pte. Ltd.'s liability for any breach of this warranty shall be limited to the purchase price (excluding installation costs) of the appliance.

* Lifestyle Products - Garment Steamer, Humidifier, Dehumidifier, Air Purifier, Mini Bar-Fridge.

* Walk-in warranty - Customers are obliged to bring the warranted products to Strategic Marketing (S) Pte. Ltd. Service Centre for repair/service during the warranty period.

Ver. 20_0312



**Scan QR Code for
the online Warranty
Registration**