



ELECTRIC STEAMBOAT WITH BBQ GRILL ESB 7421S

Instruction Manual

Thank you for purchasing EuropAce Electric Steamboat with BBQ Grill.
For safety purpose, please read this operating instruction manual carefully before using
and keep it for future reference.



RELISHING YOUR COOKERY

Celebrate Fine Living!



INTRODUCTION:

- Combination of “Chinese” steamboat with “western” BBQ cooking into one appliance.
- Unique “flat-top” tapered heater for BBQ usage while enjoying your Hot Pot.
- Heavy cast non-stick aluminum BBQ grill pan heats evenly.
- Removable pot & BBQ pan (non-stick coating) for easy cleaning.
- Ready safety light indicates cooking status.
- Transparent glass lid for proper cooking.
- Easier for anyone to make cooking.

COMPONENTS NAME:

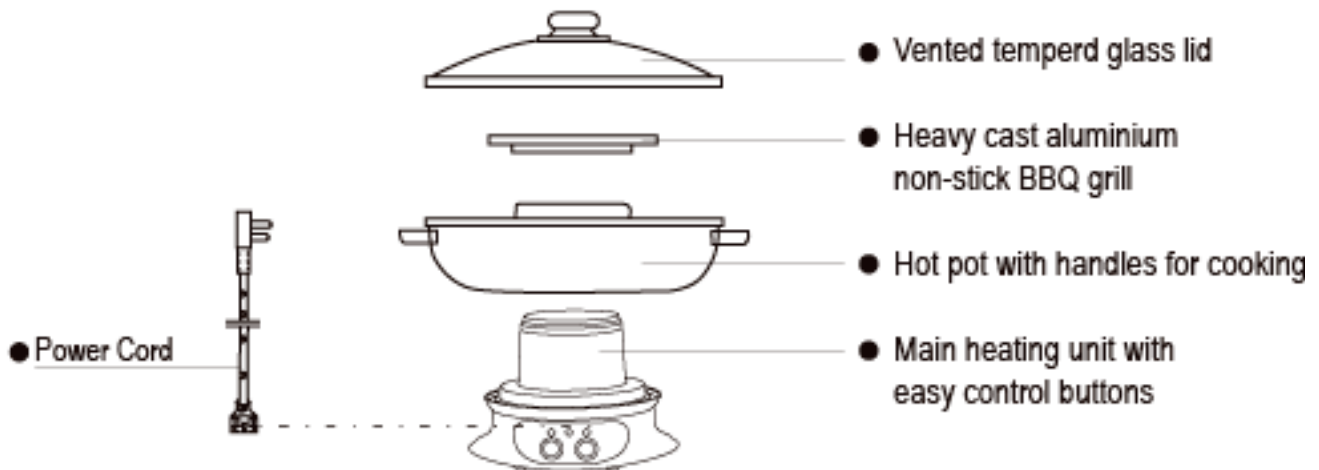

PREPARATION FOR FIRST USE:

1. Remove all packaging materials.
2. Check to make sure the appliance is undamaged. In case of any damage, immediately contact your supplier and do not use the appliance.
3. Before first use, clean the stainless steel pot thoroughly by wiping with damp sponge and mild cleaning detergent. And then bring the pot with water to boil for a few minutes. Rinse thoroughly.
4. Position the appliance in such a way that the plug is accessible at all times.

INTRODUCTION TO USE:

1. Before each operation, remove any unwanted material from the surface of the heating base and tapered heater. Ensure the pot sit firmly on the heating base before operation.
2. Put the hotpot with soup or water on the heating base and turn slightly to fit the bottom of the pot to the surface of the heating base. Fill only 70% full when cooking to avoid spillage which may result in electric hazard.
3. Plug the power cord fully into the heating base socket and turn on the power supply. Power indicator(red light) will turn on standby mode.
4. Fill the cooking pot with soup or water before placing on the heating plate.
5. The grill pan must sit on the "flat-topped" tapered heater during hotpot, to keep "flat-topped" taper heater dry.
6. Set the HOT POT button to the desired function:
 - * Set "|" for keeping the liquid warm
 - * Set "||" for heating the liquid
 - * Set "O" for switching off the HOT POT function
7. Set the GRILL button to "|", GRILL indicator will light up. To preheating the grill plate for about 5 minutes for optimum grilling results. When the required temperature has been reached, you can start grilling. Please use only wooden or plastic utensils for stirring and turning food on the grill plate. Do not use metal spoons, knives or forks. They can scratch the grill plate.
*Important: When using the grill function, never cover the appliance with the glass lid! When you no longer need the GRILL function, set the grill switch to "O".
8. After use, set the HOT POT and GRILL switch to "O" and unplug the power cord. Then unplug the femal appliance plug from the appliance and allow it to cool.

CLEANING AND MAINTENANCE:

1. Before cleaning, always turn off the appliance and unplug it from the power supply. Allow the heating base to cool, and then remove the grill plate firstly, then remove the stainless steel pot from the heating base.
2. Clean the stainless steel pot, glass lid and grill plate using water with a little dishwashing detergent added. Rinse thoroughly and dry completely.
3. Do not use any abrasive scouring agents, steel wool, metal objects, hot cleaning agents or disinfectants, since they can damage the appliance.
* Remark: "Bluish" or "rainbow" discoloration is common on stainless steel cookware and is caused by minerals or salts in food and water. Water stains can be removed with a sponge dampened in vinegar or lemon. Water stains also can be removed by adding Vinegar or lemon into water to boil for 1 minute.

4. The best way to clean the grill plate is to wipe it with a damp sponge in warm water with a little dishwashing detergent added. Do not immerse the grill plate into water for long time.
5. Wipe clean the base with a damp cloth. Do not immerse the base and power cord into water or other liquids or wash them in the dishwasher.
6. When completely dry, store the appliance in a dry, safe place so that it is protected from dust, shocks, heat and moisture.

SAFETY INTRODUCTION:

Please read the below instructions carefully before connecting the appliance in order to prevent damage due to incorrect use.

1. Connect only to a 220-240V~ wired wall socket. Do not overuse extension cord or outlet adapter.
2. Make sure the appliance and the plug do not come into contact with water or any other liquids. Should the appliance be dropped into water inadvertently, remove the plug from the electric socket immediately and have the appliance checked by a certified professional. Non-compliance with this may result in peril to life.
3. Fill water or soup not more than 70% during operation, spillage from overflow when boiled may cause electric hazard.
4. To prevent electric shock, do not immerse the appliance, the plug or the power cord into water or other liquids.
5. Never switch on the appliance with an empty pot on top of it which may result in serious damage to the appliance.
6. Do not cover the lid during BBQ or the BBQ grill pan is hot. And do not spatter other liquid than cooking oil on the hot BBQ grill pan. And do not touch the grill pan during cooking, since it is hot.
7. "Flat-topped" Tapered heater must be kept dry at all time. And it is just solely for BBQ grill pan use. Do not try to use it for other purpose.
8. Place the hot pot in a dry place. Be careful to protect the heating base against dampness and shock. And remember never to the heating base into water for cleaning.
9. Do not remove the pot from the heating plate before it cools down. Remove the pot with force may damage the pot and the heating plate.
10. Put the hotpot with soup or water on the heating base and turn slightly to fit the bottom of the pot to the surface of the heating base. Fill only 70% full when cooking to avoid spillage which may result in electric hazard.
11. Unplug from the outlet when not in use and before cleaning. Allow it to cool down before putting on or taking off parts, and before cleaning the appliance.
12. The appliance should be given ample air circulation on all sides. The heating plate has to face upwards when using.

13. Operate the appliance on a flat and dry place. Always keep the appliance dry, especially the heating plate. The appliance may be deformed or damaged when exposed to high heat or used in unstable surroundings (excess water or humidity).
14. Make sure the outer surface of the pot and the heating plate is clean and dry before plug-in.
15. Before cooking, make sure the pot is levelly placed and tightly seated in the middle of the heating plate.
16. Do not place any object near by or cover or touch the hot steam vent of the glass lid while cooking.
17. Do not use the appliance for other than its intended use.
18. Never put the removable stainless steel pot on any other cooking devices.
19. Never touch the outer body of the hotpot during operation. Always allow it to cool down before handling.
20. Extreme caution is necessary when moving appliance with hot liquid inside.
21. Not suitable for outdoor use or in damp areas. The appliance is for household use only.
22. Beware of hidden steam under the lid.
23. Do not place on or near a hot gas or electric burner, or in a heated oven. And do not place flammable material near the appliance.
24. Do not use the appliance should the following occurs:
 - *cord damaged
 - *plug damaged
 - *appliance malfunction
 - *appliance damagedDo not attempt to repair the appliance by yourself. Always return to service center for rectification.
25. Handle the power cord carefully. Do not bend or pull the cord. And do no wash or immerse it into water or any other liquids. Unplug from the outlet when not in use.
26. Power cord should not be knotted, left on hot surfaces or left hanging over table edges where it can be pulled on by or tripped over children.
27. It is normal for smoke or smell to be emitted during first use. Continue using till smoke stops.
28. This appliance is not intended for use by children, unless they have been given supervision or instruction concerning the use of the appliance by a person responsible for their safety.
29. Close supervision is necessary when the appliance is used by or near children. Never leave the appliance unattended in case children shall play with the appliance.

產品介紹

集火鍋與燒烤於一體。

野外燒烤式的獨特燒烤盤讓您盡享烹飪之美。

鋁制不粘燒烤盤，令食材均勻加熱。

可拆卸的火鍋煲和燒烤盤（不粘塗層），便於清洗。

帶有使用狀態指示燈。

透明的玻璃蓋可以隨時看到煮食狀態。

讓煮食變得更簡單。

部件名稱

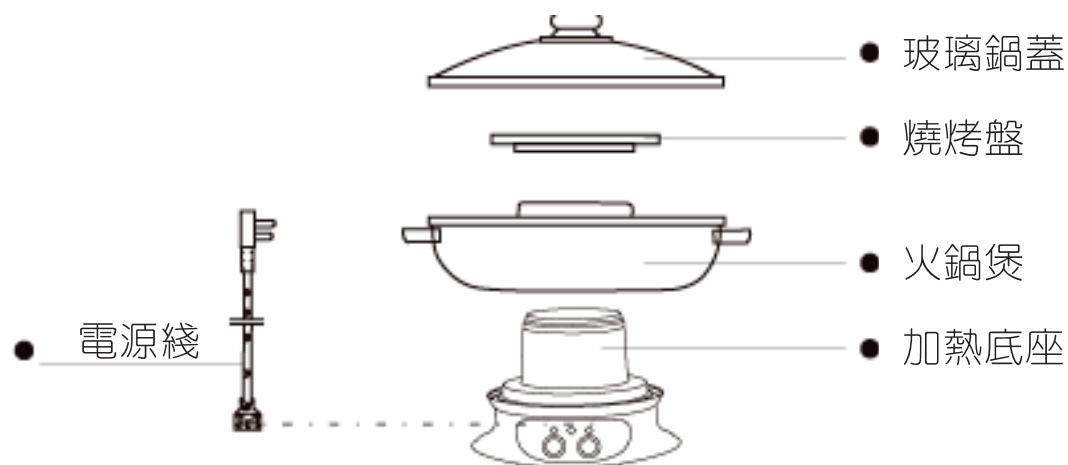

首次使用

1. 拆開包裝
2. 檢查產品是否完好，如有任何損壞，請與銷售商聯系。
3. 第一次使用前，先用洗潔精和布徹底清洗火鍋煲的內外、燒烤盤和玻璃蓋，用清水衝洗乾淨，然後往火鍋煲內注入適量清水，煮開幾分鐘。最後用抹布再清洗一遍即可。
4. 將該產品插頭正確地插在插座上。

使用說明

1. 在每次使用之前，請清除火鍋發熱盤和燒烤加熱盤上的東西，確保鍋盤能穩定放在發熱盤上。
2. 建議往火鍋煲加入7分滿分量的水或湯，以免過多的水或湯溢出而引致危險，然後平穩的將鍋放在發熱盤上。稍將鍋旋轉以確保鍋子與發熱盤已密切結合。
3. 將插頭插入插座，打開電源，電源指示燈亮，表示加熱裝置已處於準備狀態。
4. 在放置燒烤盤之前先將預先加入湯或水的火鍋煲放置好。
5. 在使用火鍋功能過程中，必須將燒烤盤放置在加熱盤上，以保持加熱盤的乾燥和清潔。
6. 火鍋控制按鈕分高低溫電力，開始煮食請按下“||”高溫電力檔位，水滾之后如需低火力，請把按鈕按至“|”低溫電力檔位，火鍋將以低火力工作。“0”為關機檔位。
7. 使用燒烤功能，在放食物前先按下GRILL按鈕至“|”開檔位，預熱燒烤盤至理想熱度再放食物燒烤。請使用木鏟或硅膠塑料類餐具翻動食物。請勿使用不銹鋼刀叉勺子，這樣會破壞燒烤盤的塗層。打開燒烤功能按鈕後，其指示燈將一直亮著，在此過程中不要蓋上蓋子，否則它將變得很燙以至於不能取走。如無需使用燒烤功能請按GRILL按鈕至“0”關機檔位。
8. 使用完後，關閉HOTPOT按鈕和GRILL按鈕至“0”關機檔位，並拔掉電源綫。

清潔與保養

1. 在清潔產品之前，請確保已經把插頭從插座上拔掉。在發熱盤冷卻後先將燒烤盤取下，再將火鍋煲取出。請注意燒烤盤燙手不要直接用手觸碰，小心燙傷。
2. 用洗潔精和布徹底清洗火鍋煲的內外，燒烤盤和玻璃蓋，最後用清水衝洗乾淨，用乾布抹乾即可。
3. 不要用具有腐蝕性的洗滌劑、鋼絲擦、金屬硬物或者刺激性的消毒劑清洗產品，這樣會損害產品。不銹鋼鍋經使用後，光澤明顯減弱或有“彩點”屬正常現象，是由食物中的鹽分和礦物質所引起，決不影響產品及食物的質量。用海綿沾濕醋或者檸檬抹擦鍋面可以去除水垢，或者放醋/檸檬和水一起煮滾一分鐘也可以去除水垢。應抹乾內鍋後才儲存起來。
4. 請愛護烤盤塗層，勿使用金屬利器刮削，清洗時請用布或海綿在溫水中拭擦清洗，不可長期浸泡水中。清洗完畢應用乾布抹幹後才儲存起來。
5. 用濕布拭擦發熱盤和不銹鋼底座，請勿將發熱盤底座和電源綫浸入水中清洗。
6. 將產品晾乾後再儲存在乾燥的地方以防止塵霧污染。

安全提示

在使用該產品之前，請認真閱讀下面的指示，以防止由於錯誤使用而造成的損害。

- 1.請使用220-240V~的電源插座供電，請勿使用電源延長綫或電源適配器。
- 2.請勿將產品和插頭與水接觸，如果不慎放入水中，請立即拔掉電源。
- 3.在使用過程中，加入不超過2.5升湯或水，以免因為液體溢出可導致漏電事故。
- 4.為了防止漏電事故，請勿將該產品、電源插頭或電源綫浸入水或其他液體中
- 5.請勿在沒有放置食材時打開該產品的電源，這樣可能會對產品造成重大損壞。
- 6.在燒烤模式下或者燒烤盤加熱的時候，請勿蓋上蓋子，也不要再熱油上加入其它液體，請勿用手觸碰燒烤盤。
- 7.燒烤發熱盤必須一直保持乾燥，它專為本產品燒烤盤設計使用，請勿嘗試將其用作其他用途。
- 8.請將火鍋煲放置於乾燥處，注意保護發熱盤，應遠離潮濕處和避免震動，請勿將其放入水中清洗。
- 9.在發熱盤冷卻之前，請勿將火鍋煲或燒烤盤從發熱盤上移走，強行將它移走可能會對產品造成損害。
- 10.在往火鍋煲加入湯或水，應調整煲的位置使它與發熱盤的接觸位置保持合適的狀態。
- 11.在不使用時或清洗之前，應拔掉電源插頭，在該產品充分冷卻後才能進行移動、拆卸和清洗。
- 12.在使用產品時應保持空氣流通，使用時發熱盤必須朝上
- 13.將該產品放置在平坦乾燥的地方，保持它的持久乾燥，特別是他的加熱板。如果放置在靠近高溫、潮濕的地方，可能會導致該產品損壞。
- 14.在插上電源之前確保火鍋煲的表面清潔乾燥。
- 15.在使用之前，確保火鍋煲放置在平坦的桌面上。
- 16.請勿在玻璃蓋排汽孔上放置任何東西。
- 17.請勿將該產品作其用途之外的使用。
- 18.請勿將可拆卸的不銹鋼火鍋煲和燒烤盤用于其他產品上。
- 19.在使用過程中不要觸碰火鍋煲的表面，必須在其經過充分冷卻後再觸碰。
- 20.在裝有滾燙液體時，應小心移動該產品。
- 21.該產品只能在室內使用，請勿在戶外或潮濕的地方使用。
- 22.注意玻璃蓋子的高溫蒸汽。
- 23.請勿將該產品放置於其他有高溫蒸汽或帶有加熱裝置的產品之上。

24.請勿在以下情況下使用：

電源綫損壞

插頭損壞

產品故障

產品損壞

請勿試圖自行修理該產品，請送到客服中心進行維修

25.請正確使用電源綫，請勿將它與其他繩子纏在一起。不要浸沒在水或其他液體中清洗，在不使用時請拔掉插頭。

26.電源綫不能打結，不能放置在很熱的地方，不要將它放在桌面邊緣，以防兒童的拖拽導致絆倒。

27.在第一次使用時可能會有少許的烟和氣味，持續使用後這種情況將會消失。

28.請勿讓兒童單獨使用該產品。

29.兒童必須在有大人監管的情況下使用該產品，使用該產品時，不要讓兒童在附近玩耍。

Product Warranty

The Warranty Card is not provided in the product packaging. You can register the product warranty online at our website <https://www.europace.com.sg/ewarranty/> within 7 (seven) days from the date of purchase. You will enjoy an additional 3 months of the product standard warranty when you register online. Please produce your E-warranty registration when requesting for repair and service at our Service Centres nearest to you.

In the event, if you are unable to register the product warranty online you must produce your purchase receipt/tax invoice and such other documentary proof of purchase of the appliance when requesting for repair and service.

Product Warranty Coverage

You may find out your product warranty coverage at the link below before calling our Customer Service Hotline (65) 6457 3678 or visiting our Service Centre.

http://europace.com.sg/ewarranty/src/cupload/settings_pdf/1/1-1-2c899-1563960978-WARRANTY-COVERAGE-19_0221.pdf

TERMS & CONDITIONS OF WARRANTY (THIS WARRANTY IS VALID IN SINGAPORE ONLY)

Your appliance is warranted against faulty design, workmanship or materials for a period of 12 months unless otherwise stated from the date of purchase, subject to the following terms & conditions herein below:-

- 1) That the owner shall register the product warranty online at our website www.europace.com.sg within 7 (seven) days from the date of purchase.
- 2) That the appliance shall be used solely for domestic purposes and not for commercial purposes or any other purposes whatsoever and used strictly under the instruction for operation as provided by the manufacturers or the appliance.
- 3) That if any time during the warranty period any part or parts of this appliance is removed, tampered, modified, adjusted, altered, handled or repaired in any way whatsoever by any persons other than those authorized by Strategic Marketing (S) Pte Ltd, this warranty shall immediately cease to be valid and become void.
- 4) That the owner shall produce the E-warranty registration or tax invoice/receipt and such other documentary proof of purchase of the appliance to our satisfaction as we may deem necessary when requesting for repair and service.
- 5) That our decision on all queries relating to complaints as to defects either of workmanship or of materials shall be conclusive and the owner shall agree to abide by such a decision. Any appliance or defective part which has been replaced shall become our property.
- 6) The terms and conditions of this warranty shall be contained exclusively in this document and no other presentation of provision, either written or otherwise, regardless of the origin of the same, shall be accepted as either adding or removing from these terms and conditions.
- 7) That this warranty shall cease to be valid and void if the appliance is exported or relocated from Singapore.
- 8) That there shall be no removal, alteration, defacement, or made illegible/tampered or any kind of the serial number on the appliance.
- 9) That the owner shall be fully responsible for the due delivery and collection of the appliance for any work done according to this warranty. Transportation expenses incurred for delivery or handling the appliance are chargeable to the owner.
- 10) Transportation and labour charges apply after the full parts warranty expires. Refer to <https://www.europace.com.sg/ewarranty/> for more information.

In addition to the above, this warranty shall be subjected to the following limitations and exclusions:-

a) The appliance shall be warranted by STRATEGIC MARKETING (S) PTE. LTD. from date of purchase only for a period of:-

10 years - Heating Element warranty applies to selected models of Storage Water Heaters.

- Tank Leakage warranty applies to selected models of Storage Water Heaters.

8 years - Motor warranty applies only to selected models of Stand Fans (Walk-in warranty).

10 years - Compressor warranty applies to selected models of Refrigerators.

6 years - Motor warranty applies only to selected models of Stand Fans (Walk-in warranty).

- Compressor warranty applies only to selected models of System Air Conditioners and Portable Air Conditioners.

5 years - Compressor warranty applies to Refrigerators, Freezers, Wine Coolers, Portable Air Conditioners & Casement Air Conditioners (Outdoor warranty). Transportation is chargeable from the 2nd year to 5th year.

- Compressor warranty applies to Dehumidifiers (Walk-in warranty)

- Motor warranty applies only to selected models of Stand Fans (Walk-in warranty).

3 years - Full parts warranty applies only to selected models of Air Purifiers & selected models of Dehumidifiers (Walk-in warranty).

- Heating Element warranty applies only to selected models of Garment Steamers (Walk-in warranty).

- Motor warranty applies only to selected models of Jet Turbine Fans & selected models of Air Coolers (Walk-in warranty).

2 years - Motor and internal parts warranty applies only to selected models of Stand Fans, selected models of Oscillation Power Fans & selected models of Air Purifiers (Walk-in warranty).

- Heating Element warranty applies to selected models of Electric Ovens & selected models of Kettle Jugs. (Walk-in warranty)

- Motor warranty applies only to selected models of Jet Turbine Fans (Walk-in warranty).

- Full parts warranty applies only to Wine Coolers of 34 Bottles & above.

1 year - Full parts warranty applies to *Lifestyle Products (cash & carry items), Small Kitchen Appliances, Fans, Air Coolers, Wine Coolers of 20 Bottles & below, Mini Bar Fridge (Walk-in warranty)

- Full parts warranty apply to Refrigerators, Air Conditioners & Freezers (Outdoor warranty).

Check out the warranty coverage of your appliance at www.europace.com.sg

b) The owner waives all or any claims to compensation monetary or otherwise which he/she may be entitled to and shall agree to accept any compensation whatsoever by way of additional repairs or otherwise which we in our absolute discretion may deem fit to offer. The giving of compensation shall be subjected to the other provisions of the warranty.

c) This warranty shall not be transferable, negotiable or assignable to any third party.

d) The warranty does not include transport delivery or handling charges incurred in the transportation of the appliance to and from Strategic Marketing (S) Pte Ltd.

e) Damage caused during transit where the appliance is transported for servicing, repair, or in relation thereof or connection therewith.

f) In respect of refrigerator and air conditioner only, upon the expiry of 12 months from the date of purchase, this warranty will not cover transport, refrigerant and labour to install a new compressor.

g) This warranty will not cover chemical cleaning, maintenance service, general service and overhaul, which if confirm is chargeable.

h) Defects or fault in the appliance which has been used for commercial purposes or which have been rented/leased or which have been otherwise subject to other than household use.

i) Claims for damaged/missing parts after 3 days from the original date of goods received will not be valid.

j) This warranty and the Replacement Scheme does not particularly cover damages and/or defects arising from

- Usage of wrong electrical supply/voltage.
- Usage not according to the Instruction Manual provided by the manufacturers.
- Misuse, accidents, negligence, abuse, improper installation, or any manner of tampering.
- Normal wear and tear.
- Corrosions rusting or stains.
- Scratches, dents on the unit body, casing or paintwork of the appliance.
- Act of God, fire, flood and civil unrest.
- We shall not under any obligation, legal or otherwise to repair this appliance or one to one exchange if the same shall be required as a result of losses, damages, and malfunctions arising from any of the causes mentioned in the paragraph.

k) All accessories, external parts and extruded parts such as front panel, casing, door, glass cover, glass door, cable/cord assembly, batteries, adaptor, plug, remote control, control knob, buttons, filter, UV lamp, oven tray, wooden rack, exhaust hose, fixtures, panels, cover, lid and lever, plastic parts, fan blades, blade guard, inner pots, brushes, water tanks, attachments made of glass, plastic and/or porcelain, detachable parts, and other option items are excluded from this warranty.

All services provided after the warranty period will be chargeable at standard rates determined by STRATEGIC MARKETING (S) PTE. LTD.

The terms and conditions of this warranty shall be varied except with the written and express consent or agreement of Strategic Marketing (S) Pte. Ltd. While Strategic Marketing (S) Pte. Ltd. endeavours to repair any defects after the warranty period, it is subject to availability.

It is hereby expressly provided that any liability of Strategic Marketing (S) Pte. Ltd. for any loss or damage whatsoever arising from, relating to or in connection with the purchase of the appliance shall not exceed the purchase price (excluding installation costs) of the appliance. Similarly, Strategic Marketing (S) Pte. Ltd.'s liability for any breach of this warranty shall be limited to the purchase price (excluding installation costs) of the appliance.

* Lifestyle Products - Garment Steamer, Humidifier, Dehumidifier, Air Purifier, Mini Bar-Fridge.

* Walk-in warranty - Customers are obliged to bring the warranted products to Strategic Marketing (S) Pte. Ltd. Service Centre for repair/service during the warranty period.



**Scan QR Code for
the online Warranty
Registration**

Ver. 20 _0312

For more technical details / enquiries, please visit:

EUROPACE SERVICE CENTER

10 Changi South Street 3 #06-01 Singapore 486147

Tel: (65) 6457 3678 | Fax: (65) 6741 0728

Operating Hours: Monday-Friday: 9am - 5pm | Saturday: 9am - 12pm

Email: service@strategic.com.sg

www.europace.com.sg | www.strategic.com.sg

RELATED PRODUCTS & MAIN CONTACT HOTLINE

System Split Aircons | Tel: 6858 0801 | Email: systemac@strategic.com.sg (Twin City)
Portable & Casement Aircons | Tel: 6291 0800 | Email: portableac@strategic.com.sg (Jia Yue)
Refrigerators, Washing machines, Cookers & other major appliances |
Tel: 6289 0802 | Email: mda@strategic.com.sg (TnG)

Celebrate Fine Living!

This product is distributed by Strategic Marketing (S) Pte Ltd

If there is any technical amendment for the product, it will be edited on the updated version of the instruction manual without prior notice. The pictures shown in the instruction manual is only for illustration purpose only. If the appearance or colour of the product is modified, please refer to the actual appliance as a standard.