

EuropAce®
TRUSTED SINCE 1992



2-IN-1 12L FOOD STEAMER EFS 2121W



Celebrate Fine Living!

Thank you for purchasing EuropAce Products.
For safety purpose, please read this operating instruction manual carefully before using
and keep it for future reference.

CONTENTS

Title	Page No.
Parts Introduction	1
Technical Specifications	1
Before Using	2
How to Operate Food Steamer	2
Cleaning and Maintenance	3
Important Guidelines	4

Parts Introduction

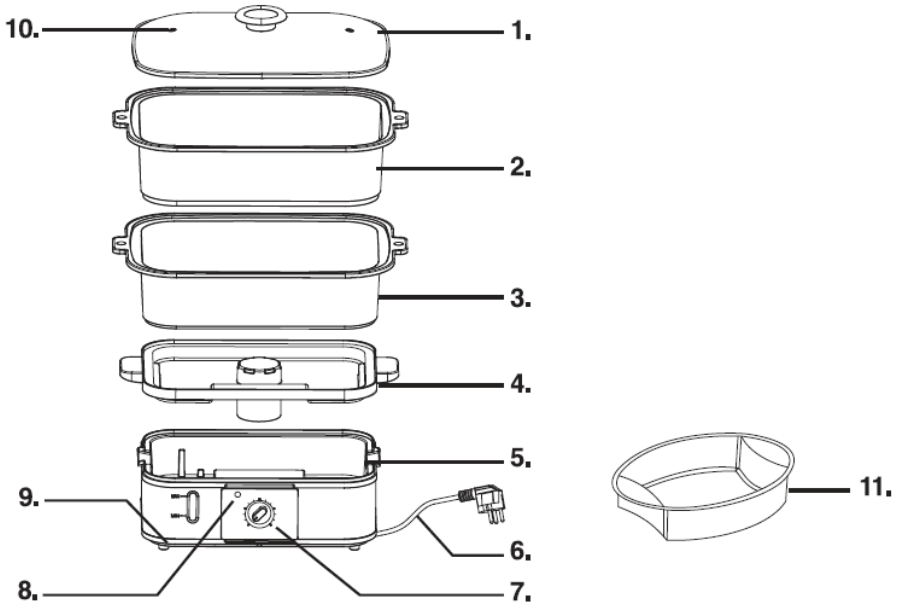

- | | |
|----------------|--------------------|
| 1. Steamer Lid | 7. Timer Knob |
| 2. Steam Bowl | 8. Indicator Light |
| 3. Steam Bowl | 9. Base |
| 4. Drip Tray | 10. Steam Vent |
| 5. Reservoir | 11. Rice bowl |
| 6. Power Cord | |

Technical Specifications

Voltage	220-240V ~
Frequency	50/60Hz
Power	800W
Capacity	12L

Warning: This appliance must be earthed.

Before Using

- Please read these instructions carefully before use and keep them for future reference.
- Check your local main voltage whether it is the same as stated on the rating label.
- Before using for the first time, remove any protective film or sticker from the appliance.
- Clean the steam bowls thoroughly before use.
- Make sure the switch is on “OFF” position before plugging.
- Fill up the reservoir with water to the maximum mark and assemble the steam bowls, steam lid and drip tray. Operate the steamer for 30 minutes and discard the water.

How to operate the Food Steamer

- Place the food steamer on a stable surface away from walls.
- Fill up the reservoir with water. Make sure the water level in the reservoir is in between the maximum and minimum mark.
- Water added to the minimum mark can be steamed for about 1 hour while water added to the maximum mark can be steamed up to 2 hours.

(Note: Do not add any salt, pepper, flavoring, essence, wine or other liquids into the reservoir.)

- Place drip tray in motor unit covering the reservoir and make sure it sits flat.
- The appliance can be used in three ways:
 - i) Using one steam bowl:** Place food in the steam bowl, then position the bowl at the base.
 - ii) Using two steam bowls:** First put the big-sized food in the lower steam bowl and place it at the base. Then, place another steam bowl on top and place the food in it.
 - iii) Using rice bowl:** Add water and rice into rice bowl. Then, place the rice bowl in the steam bowl. Refer to the recommended measurements.

(Note: Do not overfill the steam bowl, thereby blocking the steam vent in the lid. The steam must be able to circulate and escape freely.)

- Cover with the steamer lid.
- Insert the plug into the power outlet.
- Set the timer to the recommended time, and make sure the steamer is switched on before setting the timer. Once the indicator light is on, steam will be produced in a short time.

(Note: Condensation during steaming is normal. If longer cooking time required, water may be added to the reservoir.)

- When steaming is completed, a chiming sound will be heard and the appliance will be switched off automatically.

Recommended Steaming Time

Type	Measurements	Water Level	Steaming Time (Min)
Rice	Rice 1/2 cup Water 1/2 cup	Minimum	30 – 45
Asparagus	450g	Minimum	10 – 12
Broccoli	225g	Minimum	06 – 10
Cabbage	225g	Minimum	08 – 11
Sliced carrots	225g	Minimum	08 – 10
Cauliflower	225g	Minimum	11 – 14
Chicken breasts	2 pieces	Minimum	27 – 35
Clam	450g	Minimum	08 – 12
Corn	750g	Minimum	18 – 20
Crab	2 pieces	Minimum	38 – 40
Hard-boiled egg	6 pieces	Minimum	12 – 22
Fish fillets	225g	Minimum	18 – 35
Peas	280g	Minimum	12 – 15
Sliced potatoes	225g	Minimum	08 – 10
Sausages	5 pieces	Minimum	18 – 22
Prawns	450g	Minimum	08 – 12

Note: The time or weights above mentioned are only for references. You may adjust them according to the type of food, weight, thickness or taste for better results. Once you are familiar with the appliance, adjust the steaming time according to your preferences.

Cleaning and Maintenance

- Make sure the power cord is unplugged prior to cleaning.
- Allow the cooker to cool down.
- After each usage, empty and wash the steaming bowls, steamer lid and drip tray with warm soapy water. Then, rinse and dry the parts.
- Discard the remaining water in the reservoir and clean the reservoir with soapy water and dry it with a soft cloth. Wipe outer surfaces of the base with a damp cloth.
- Do not submerge the base in water or any other liquid.
- Descale the reservoir occasionally as mineral deposits may build up in the reservoir after some time. When the production of steam has slowed down, the reservoir needs to be descaled.

(Note: It is essential to descale the reservoir in order to prolong the product's lifespan. The amount of deposits depends on the hardness of water in your living area.)

- To descale the reservoir, fill the reservoir with the mixture of vinegar and water to the maximum mark. Do not use any other chemical or descaler.
- Insert the plug into the power outlet and assemble the steam bowls and steamer lid to the base.
- Set timer to approximately 20-25 minutes to start steaming. In case white vinegar is overflowing from the reservoir, unplug the appliance. Switch off timer and reduce some amount of white vinegar.
- When the timer stops, unplug the appliance and allow it to cool down before pouring out the white vinegar.
- Rinse the reservoir and other parts with water and dry them thoroughly.

Important Guidelines

- Do not operate the appliance without steam bowls and steamer lid.
- Do not touch the base, steam bowls and the steamer lid as the surface might be hot. Always use gloves when handling the food steamer.
- When removing the drip tray, be careful as the water in the reservoir might be still hot.
- Do not open the lid when cooking.
- When using the appliance at high altitude, steaming time may need to be increased.
- Steaming time stated in recipes is only for reference. It also depends on food size, location, freshness and taste. When you are used to the functionalities of the steamer, you could set time easily.
- Simple layer food steams faster than multi-layer food. Therefore, steaming time for large quantity of food will be longer.
- For better results, select proper size of food to steam. If food size is different greatly, place the smaller food on the top.
- Do not overload the steaming bowls with food. There should be sufficient space in between the food for maximum steam flow.
- Liquid in drip tray can be used to make soup, sauces or gravy.
- Defrost frozen meat or poultry before steaming.
- The steaming time stated in recipes is based on the use of cold water.
- Rice bowl can be used to steam food such as fruits, vegetables, pudding, quick bread, etc.
- When using two steam bowls, always place the food with long steaming time in the lower steam bowl.
- When steaming meat and vegetables, always place meat in the lower layer so that gravy would not drip onto other food.

- Steaming time for food in the upper steam bowl is usually 5 minutes longer than other levels' steaming bowls. If you need to steam food with different cooking time, start steaming food with the longest cooking time first in the lower steam bowl.
- Use only original accessories supplied.
- The current voltage which indicates on the appliance must correspond to your local voltage.
- Do not operate the appliance unless it is fully assembled.
- Do not overload outlets or extension cords. It may result in fire or electric shock.
- This food steamer is intended for indoor and household use only. It is not for outdoor, commercial and industrial use.
- Do not immerse the cord, plug or appliance in water or other types of liquid and do not pour water onto it to avoid from fire, electric shock or injuries.
- To protect against the risk of electric shock, do not force any foreign objects such as pins and wires into any openings.
- Do not pull the cord to remove the plug from the wall socket, pull on the plug instead.
- Do not attempt to insert or remove the plug with wet hands.
- Do not allow children to use electrical equipment without adults' supervision.
- The appliance is not intended to be controlled by an external timer or separate remote-control system.
- This appliance should not be used by the physically challenged, slow response or mentally disabled people (including children) unless guidance is provided during operation.
- Do not operate any appliance with a damaged cord or plug, or after the appliance malfunctions or has been damaged in any manner. Repair and services should always be carried out by PENSONIC Customer Care/Service Centre.

	<p>This marking indicates that this product should not be disposed with other household wastes throughout the nation. To prevent possible harm to the environment or human health from uncontrolled waste disposal, recycle it responsibly to promote the sustainable reuse of material resources. To return your used device, please use the return and collection systems or contact the retailer where the product was purchased. They can take this product for environmental safe recycling.</p>
---	--

重要的安全说明：

使用本产品时，请遵守以下安全注意事项：

- 请仔细阅读这些说明，以便从您的设备中获得最佳使用效果。
- 如果他们已被给予监督或在安全的使用方式指导下，如果他们了解所涉及的危险，8岁及以上的儿童可以使用本设备。清洁和用户维护不得由儿童进行，除非他们超过8岁并接受监督。请将设备及其电线放在8岁以下儿童接触不到的地方。
- 连接电器前，请检查电器底部显示的电压是否与您家中的主电压一致。
- 请找到电源插座可触及的设备。
- 仅供家庭和室内使用，本产品必须按照国家配件标准安装。
- 产品必须接地。如果插座或电源没有接地连接，则不得连接设备。
- 如果电源线损坏，必须由制造商、其服务代理或类似的合格人员更换，以避免危险。
- 注意这台机器产生的蒸汽会灼伤你。
- 在打开盖子的时候，请注意不要被从蒸锅里喷出来的蒸汽烫伤。
- 处理任何东西时要小心：任何液体、蒸汽或冷凝物。
- 机器会非常热，建议使用烤箱手套。
- 该设备适用于家庭。
- 插入之前，确保开关处于“关闭/OFF”位置。
- 烹饪时建议不要打开盖子。
- 烹饪时，本体是热的，在它冷却之前不要碰它。
- 为了降低触电的风险，只能在可移动的容器中烹饪。
- 首次使用前，请仔细检查设备的所有部件是否完好。如果没有，请联系供应商或制造商。
- **如果设备状况不佳，请勿使用。**
- 适用于蒸食物。
- 设备运行时，表面温度会变得非常高。

首次使用:

首次使用前，请仔细检查电器的所有部件是否完好，如果没有，请联系供应商或制造商。

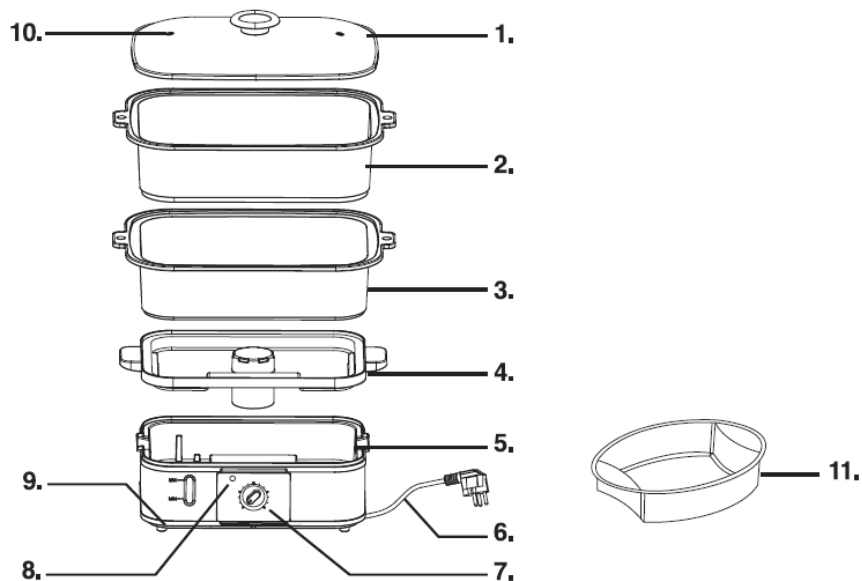

烹饪:

- 将所需量的冷自来水倒入水箱(参考烹饪指南)，不要超过最大水位线(参考水箱内侧的标记)，不要在水箱里放任何其他东西，包括放酒、肉蔬汤或任何其他液体在水箱里面。
- 将食物放在蒸格中，烹饪结束前不要添加香草或香料。
- 将盖子盖在蒸格上，确保盖子的把手与蒸格的把手完全对齐，蒸格不要放过量食物，否则会堵住盖子上的出气孔(蒸汽必须能够循环并自由地逸出)。
- 将蒸格放在底座上。
- 插上蒸锅电源。
- 在大多数情况下，倒入水箱的水足以蒸熟食物。
- 如果出于个人口味的需要，或者如果一些食物需要较长的烹饪时间，可以将水加入到容器中，并按照说明继续蒸食物。
- 烹饪完成后，拔掉电源线，小心地取出蒸格。
- 轻轻掀开盖子，以免烫伤自己(蒸汽可能会烫伤)。

● 上菜时，将盖子翻过来，滑到蒸锅下面。祝您有个好胃口！

除垢:

该设备应每月除垢一次，或每 30 次使用后除垢一次。

- 1.安装水箱，加入 200 毫升家用电器除垢剂，然后将水箱注满水，直至达到最高水位。
- 2.安装接油盘、一个蒸格和盖子。
- 3.插上电，打开电源，让蒸锅运转 5 分钟。
- 4.关闭并拔下电器插头，让其静置一夜。
- 5.清空并丢弃除垢液。
- 6.用温肥皂水清洗可拆卸水箱、接油盘、蒸格和盖子，然后晾干。
- 7.用淡水重新注满水箱，重新安装部各配件，并让其运行 5 分钟。清空并丢弃所有剩余的水。
- 8.用温肥皂水清洗水箱、水箱、接油盘、蒸格和盖子。
- 9.该设备现在可以使用了。

注意事项:

在清洗炊具之前，必须拔掉插头，并且在再次使用炊具之前，必须将插头擦干。

如果电源线损坏，请勿使用炊具。

如果炊具上的电源线损坏，只能由制造商认可的维修中心更换，因为需要特殊工具。

出于清洁目的，不得将炊具浸入食槽中。

不要将炊具用于其预期用途以外的目的。

不要在没有水的情况下使用炊具。

提示：

连接电源前，倒入所需量的冷水。如果电源线损坏，为了避免危险，必须由制造商、其售后服务人员或同等资质的人员进行更换。

蒸汽烹饪指南：

		水位	时间(分钟)。(
芦笋	450g	MIN 水位线	10-12
花椰菜	225g	MIN 水位线	06-10
卷心菜	225g	MIN 水位线	8-11
切片胡萝卜	225g	MIN 水位线	8-10
花椰菜	1 颗	MIN 水位线	11-14
鸡胸肉	2 片	MIN 水位线	27-35
蛤	450g	MIN 水位线	8-12
玉米	3 个	MIN 水位线	18-20
蟹	2 个	MIN 水位线	38-40
煮鸡蛋	6 个	MIN 水位线	12-22

规格:

电压	220-240V~
频率	50/60Hz
功率	800W

注意:



如果该标志出现在产品上，则意味着该设备的处置属于关于废弃电气和电子设备(WEEE)的第 2012/19/EU 号指令的范围。

电气和电子设备中包含的任何危险物质在再加工过程中都可能对环境和人类健康产生潜在影响。

因此，在该设备的使用寿命结束时，不应将其与未分类的城市垃圾一起处置。

就再利用、回收或从中获得其他类型的价值创造而言，您作为最终消费者的角色至关重要。你可以选择由地方当局(回收中心)和经销商组织的收集和交易系统。

您有义务进行这些选择。

Product Warranty

The Warranty Card is not provided in the product packaging. You can register the product warranty online at our website <https://www.europace.com.sg/ewarranty/> within 7 (seven) days from the date of purchase. You will enjoy an additional 3 months of the product standard warranty when you register online. Please produce your E-warranty registration when requesting for repair and service at our Service Centres nearest to you.

In the event, if you are unable to register the product warranty online you must produce your purchase receipt/tax invoice and such other documentary proof of purchase of the appliance when requesting for repair and service.

Product Warranty Coverage

You may find out your product warranty coverage at the link below before calling our Customer Service Hotline (65) 6457 3678 or visiting our Service Centre.

http://europace.com.sg/ewarranty/src/cupload/settings_pdf/1/1-1-2c899-1563960978-WARRANTY-COVERAGE-19_0221.pdf

TERMS & CONDITIONS OF WARRANTY (THIS WARRANTY IS VALID IN SINGAPORE ONLY)

Your appliance is warranted against faulty design, workmanship or materials for a period of 12 months unless otherwise stated from the date of purchase, subject to the following terms & conditions herein below:-

- 1) That the owner shall register the product warranty online at our website www.europace.com.sg within 7 (seven) days from the date of purchase.
- 2) That the appliance shall be used solely for domestic purposes and not for commercial purposes or any other purposes whatsoever and used strictly under the instruction for operation as provided by the manufacturers or the appliance.
- 3) That if any time during the warranty period any part or parts of this appliance is removed, tampered, modified, adjusted, altered, handled or repaired in any way whatsoever by any persons other than those authorized by Strategic Marketing (S) Pte Ltd, this warranty shall immediately cease to be valid and become void.
- 4) That the owner shall produce the E-warranty registration or tax invoice/receipt and such other documentary proof of purchase of the appliance to our satisfaction as we may deem necessary when requesting for repair and service.
- 5) That our decision on all queries relating to complaints as to defects either of workmanship or of materials shall be conclusive and the owner shall agree to abide by such a decision. Any appliance or defective part which has been replaced shall become our property.
- 6) The terms and conditions of this warranty shall be contained exclusively in this document and no other presentation of provision, either written or otherwise, regardless of the origin of the same, shall be accepted as either adding or removing from these terms and conditions.
- 7) That this warranty shall cease to be valid and void if the appliance is exported or relocated from Singapore.
- 8) That there shall be no removal, alteration, defacement, or made illegible/tampered or any kind of the serial number on the appliance.
- 9) That the owner shall be fully responsible for the due delivery and collection of the appliance for any work done according to this warranty. Transportation expenses incurred for delivery or handling the appliance are chargeable to the owner.
- 10) Transportation and labour charges apply after the full parts warranty expires. Refer to <https://www.europace.com.sg/ewarranty/> for more information.

In addition to the above, this warranty shall be subjected to the following limitations and exclusions:-

a) The appliance shall be warranted by STRATEGIC MARKETING (S) PTE. LTD. from date of purchase only for a period of:-

10 years - Heating Element warranty applies to selected models of Storage Water Heaters.
- Tank Leakage warranty applies to selected models of Storage Water Heaters.

8 years - Motor warranty applies only to selected models of Stand Fans (Walk-in warranty).

10 years - Compressor warranty applies to selected models of Refrigerators.

6 years - Motor warranty applies only to selected models of Stand Fans (Walk-in warranty).
- Compressor warranty applies only to selected models of System Air Conditioners and Portable Air Conditioners.

5 years - Compressor warranty applies to Refrigerators, Freezers, Wine Coolers, Portable Air Conditioners & Casement Air Conditioners (Outdoor warranty). Transportation is chargeable from the 2nd year to 5th year.

- Compressor warranty applies to Dehumidifiers (Walk-in warranty)

- Motor warranty applies only to selected models of Stand Fans (Walk-in warranty).

3 years - Full parts warranty applies only to selected models of Air Purifiers & selected models of Dehumidifiers (Walk-in warranty).

- Heating Element warranty applies only to selected models of Garment Steamers (Walk-in warranty).

- Motor warranty applies only to selected models of Jet Turbine Fans & selected models of Air Coolers (Walk-in warranty).

2 years - Motor and internal parts warranty applies only to selected models of Stand Fans, selected models of Oscillation Power Fans & selected models of Air Purifiers (Walk-in warranty).

- Heating Element warranty applies to selected models of Electric Ovens & selected models of Kettle Jugs. (Walk-in warranty)

- Motor warranty applies only to selected models of Jet Turbine Fans (Walk-in warranty).

- Full parts warranty applies only to Wine Coolers of 34 Bottles & above.

1 year - Full parts warranty applies to *Lifestyle Products (cash & carry items), Small Kitchen Appliances, Fans, Air Coolers, Wine Coolers of 20 Bottles & below, Mini Bar Fridge (Walk-in warranty)

- Full parts warranty apply to Refrigerators, Air Conditioners & Freezers (Outdoor warranty).

Check out the warranty coverage of your appliance at www.europace.com.sg

b) The owner waives all or any claims to compensation monetary or otherwise which he/she may be entitled to and shall agree to accept any compensation whatsoever by way of additional repairs or otherwise which we in our absolute discretion may deem fit to offer. The giving of compensation shall be subjected to the other provisions of the warranty.

c) This warranty shall not be transferable, negotiable or assignable to any third party.

d) The warranty does not include transport delivery or handling charges incurred in the transportation of the appliance to and from Strategic Marketing (S) Pte Ltd.

e) Damage caused during transit where the appliance is transported for servicing, repair, or in relation thereof or connection therewith.

f) In respect of refrigerator and air conditioner only, upon the expiry of 12 months from the date of purchase, this warranty will not cover transport, refrigerant and labour to install a new compressor.

- g) This warranty will not cover chemical cleaning, maintenance service, general service and overhaul, which if confirm is chargeable.
- h) Defects or fault in the appliance which has been used for commercial purposes or which have been rented/leased or which have been otherwise subject to other than household use.
- i) Claims for damaged/missing parts after 3 days from the original date of goods received will not be valid.
- j) This warranty and the Replacement Scheme does not particularly cover damages and/or defects arising from
- Usage of wrong electrical supply/voltage.
 - Usage not according to the Instruction Manual provided by the manufacturers.
 - Misuse, accidents, negligence, abuse, improper installation, or any manner of tampering.
 - Normal wear and tear.
 - Corrosions rusting or stains.
 - Scratches, dents on the unit body, casing or paintwork of the appliance.
 - Act of God, fire, flood and civil unrest.
 - We shall not under any obligation, legal or otherwise to repair this appliance or one to one exchange if the same shall be required as a result of losses, damages, and malfunctions arising from any of the causes mentioned in the paragraph.
- k) All accessories, external parts and extruded parts such as front panel, casing, door, glass cover, glass door, cable/cord assembly, batteries, adaptor, plug, remote control, control knob, buttons, filter, UV lamp, oven tray, wooden rack, exhaust hose, fixtures, panels, cover, lid and lever, plastic parts, fan blades, blade guard, inner pots, brushes, water tanks, attachments made of glass, plastic and/or porcelain, detachable parts, and other option items are excluded from this warranty.

All services provided after the warranty period will be chargeable at standard rates determined by STRATEGIC MARKETING (S) PTE. LTD.

The terms and conditions of this warranty shall be varied except with the written and express consent or agreement of Strategic Marketing (S) Pte. Ltd. While Strategic Marketing (S) Pte. Ltd. endeavours to repair any defects after the warranty period, it is subject to availability. It is hereby expressly provided that any liability of Strategic Marketing (S) Pte. Ltd. for any loss or damage whatsoever arising from, relating to or in connection with the purchase of the appliance shall not exceed the purchase price (excluding installation costs) of the appliance. Similarly, Strategic Marketing (S) Pte. Ltd.'s liability for any breach of this warranty shall be limited to the purchase price (excluding installation costs) of the appliance.

* Lifestyle Products - Garment Steamer, Humidifier, Dehumidifier, Air Purifier, Mini Bar-Fridge.

* Walk-in warranty - Customers are obliged to bring the warranted products to Strategic Marketing (S) Pte. Ltd. Service Centre for repair/service during the warranty period.

Ver. 20_0312



**Scan QR Code for the online
Warranty Registration**

For more technical details / enquiries, please visit:

EUROPACE SERVICE CENTER

10 Changi South Street 3 #06-01 Singapore 486147

Tel: (65) 6457 3678 | Fax: (65) 6741 0728

Operating Hours: Monday - Friday: 9am - 5pm | Saturday: 9am - 12pm

Email: service@strategic.com.sg

www.europace.com.sg | www.strategic.com.sg

RELATED PRODUCTS & MAIN CONTACT HOTLINE

System Split Aircons | Tel: 6858 0801 | Email: systemac@strategic.com.sg (Twin City)

Portable & Casement Aircons | Tel: 6291 0800 | Email: portableac@strategic.com.sg (Jia Yue)

Refrigerators, Washing machines, Cookers & other major appliances |

Tel: 6289 0802 | Email: mda@strategic.com.sg (TnG)

Celebrate Fine Living!

This product is distributed by Strategic Marketing (S) Pte Ltd

If there is any technical amendment for the product, it will be edited on the updated version of the instruction manual without prior notice. The pictures shown in the instruction manual is only for illustration purpose only. If the appearance or colour of the product is modified, please refer to the actual appliance as a standard.