

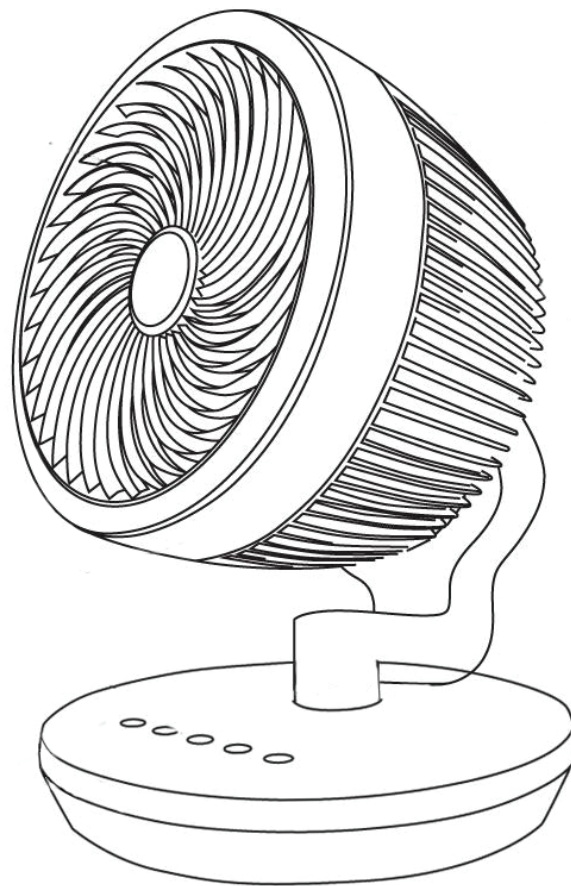

TRUSTED SINCE 1992

# 9" Jet Turbine Desk Fan

## EJF 6981V



*Celebrate Fine Living!*

Thank you for purchasing EuropAce 9" Oscillating Jet Turbine Fan.  
For safety purpose, please read this operating instruction manual carefully before using and  
keep it for future reference.

## Contents 目錄

	Page
Important safety instructions _____	3-4
Parts description _____	4
Operating instructions _____	5-6
Cleaning and Maintenance _____	6
Specifications _____	6
安全注意事項 _____	7-8
結構簡圖 _____	8
使用說明 _____	8-9
清潔及維護 _____	9
技術參數 _____	10

## IMPORTANT SAFETY INSTRUCTIONS

1. Read all instructions carefully and keep this manual for future reference.
2. This appliance can be used by children aged from 8 years and above and persons with reduced physical, sensory or mental capabilities or lack of experience and knowledge if they have been given supervision or instruction concerning use of the appliance in a safe way and understand the hazards involved. Children shall not play with the appliance. Cleaning and user maintenance shall not be made by children without supervision.
3. Do not let the appliance touch any hot surfaces.
4. To avoid electric shock, do not place the cord, the plug or the appliance in water or other liquids.
5. Close supervision is necessary when the appliance is used by or near the children.
6. Unplug the plug outlet when not in use and before cleaning.
7. Do not operate the appliance with a damaged cord or plug or after the appliance malfunctions or has been damaged in any manner- Return the appliance to our customer service centre for examination.
8. Do not let the cord hang over the edge of a table or counter or touch hot surfaces. Do not place the appliance on an unsteady or cloth-covered surface.
9. Please check the power cord & the plug firstly to see if they are normal, and check the body to see if there is any a crack or damages. If there is any abnormal, please call the customer service hotline for assistance.
10. When you are going to move the fan or not in use, please cut off the power and unplug the plug.
11. Do not use the fan in the area at high humidity, a temperature higher than 40°C or dusty area.
12. Do not insert the fingers or another object into the fan during operation. Especially take care of the children.
13. Please do not blow to the elder, the children or the patient directly for a long time.
14. Do not spray any detergent such as bug or mosquito killer into the fan to prevent it from damages to the plastic material.

15. The appliance is for household use only. Do not use it outdoors or for any commercial or industrial purpose.
16. This appliance is not intended for use by persons (including children) with reduced physical, sensory or mental capabilities, or lack of experience and knowledge unless they have been given supervision or instruction concerning use of the appliance by a person responsible for their safety.
17. Children should be supervised to ensure that do not play with the appliance.
18. Always disconnect the mains power, before any user maintenance.
19. If the supply cord is damaged, it must be replaced by the sole distributor, its service agent or similarly qualified persons in order to avoid a hazard.
20. Please ensure that the fan is switched off from the supply mains before removing the guard.
21. Only use on 220-240V AC, 50-60Hz power supply.
22. Do not operate the fan in the presence of explosive and/or flammable fumes.
23. Do not place the fan or any parts near an open flame, cooking or other heating appliance.
24. Do not hang or mount the fan on a wall or ceiling.
25. Do not operate if the fan housing is damaged.

## **PARTS DESCRIPTIONS**

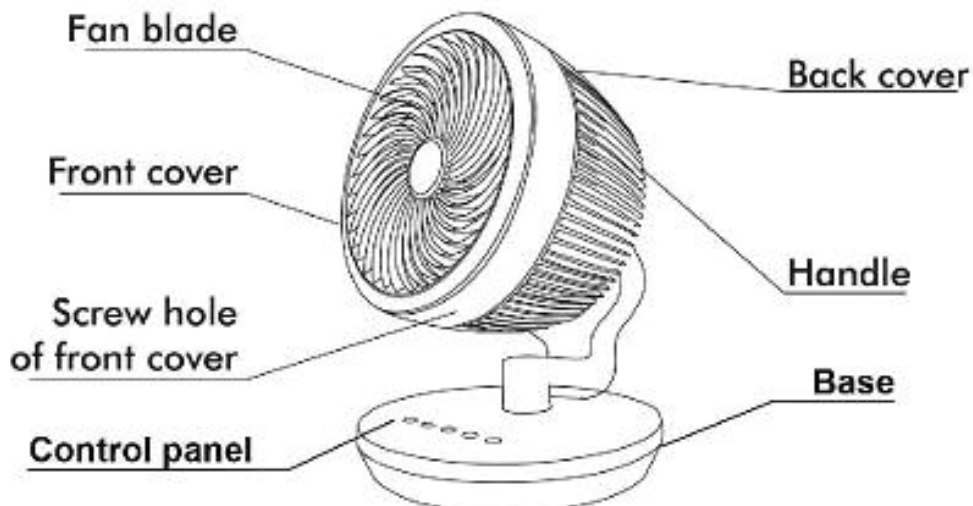

## OPERATING INSTRUCTIONS

1. Check the household voltage to ensure it matches the appliance's rated specification. Be sure to plug into a 220-240V~, 50-60Hz outlet.

2. Put in the plug, you can hear "Bi, Bi" then press the "ON/OFF", the product starts to work.

### 3. SPEED:

The product has 8 speeds with 8 LED light, and one light means a speed. You can adjust the speed by press "-" and "+" key. When you choose a speed, the light will on in the form of accumulation. For example, if you choose the first speed, then one light on; if you choose the second speed, then two light on.

### 4. MODE:

Press "Mode", you can choose the normal model, nature model or sleeping model. When you chose the nature model or sleeping model, the corresponding indicator light will on.

### 5. TIMER: (Re-set the timer after restarting the fan every time)

Product has been setting on Max 7 hours base on accumulation, it means 1H-2H-3H-4H-5H-6H-7H-0-1H.

### 6. CHILD LOCK:

Press the "On/Off" for 3 seconds, the "Child Lock" will starts working and the On/Off indicator light turns red, in the case, just the "Child Lock" function can work, others can't be operated. You can press the "On/Off" for 3 seconds again to cancel this function.

### 7. OSC:

(1) Press the "☺", the product will oscillate left and right by automatic, and press the second time, it will stop this function.

(2) Press the "☺", the product will oscillate up and down by automatic, and press the second time, it will stop this function.

8. The indicator lights will brightness by half after 15seconds if there is no operation.

9. If you don't use the fan for a long time, please pull out the plug.

## CLEANING AND MAINTENANCE

- Always turn off and unplug the fan before cleaning.
- Use only a soft, damp cloth to gently wipe the outer surfaces of the fan clean.
- To clean between the grilles, we recommend using a pipe cleaner, flexible dust wand, vacuum cleaner or compressed air to gently remove the dust.
- DO NOT immerse the fan in water and never allow water to drip into the motor housing.
- DO NOT use gasoline, paint thinner or other chemicals to clean the fan.
- For storage, you may leave the fan assembled and covered to protect it from dust. Store the fan in a cool, dry, place.

## SPECIFICATION

Rated voltage	220-240V~
Rated frequency	50-60 Hz
Rated wattage	35W
Product size	260 x 270 x 358mm
N.W.	3.15kg
G.W.	3.86kg

## 安全注意事項

1. 請細閱以下使用守則，並保留作日後參考。
2. 此設備可供 8 歲以上兒童使用，對於肢體、感官、心智殘缺或缺乏經驗和知識的人，如果他們已獲得監督和安全使用該設備的指導，並且了解其中的危害，也可使用本設備。兒童不應將本產品用於玩耍、清潔和保養，不得讓兒童在沒有監督的情況下實施。
3. 切勿讓機身觸碰任何熱表面。
4. 為避免觸電，切勿把電綫、電插頭或機身浸於水或其他液體中。
5. 兒童在使用或接近本產品時，成日應加倍留意。
6. 清洗前或不在使用時，應把電插頭從電源插座內拔出。
7. 若電綫、電插頭有損壞，或本產品本身不能運作或受損，切勿繼續使用，應交回本公司之維修中心進行維修。
8. 切勿把電綫掛在桌邊或櫃台，或觸碰任何熱的表面。切勿把本產品放在凹凸不平或鋪上布的位置上。
9. 當第一次使用時，請注意電插頭及電源是否正常，機身是否有刮花或損壞，如發現此情況，請通知本維修中心。
10. 如需搬動此風扇或不在使用時，請將電插頭從插座拔出。
11. 於下列地方，請勿使用此風扇：濕度高，氣溫超過 40°C 或充滿塵埃的地方。
12. 當電風扇在使用時，請勿將手指或其它對象放入電風扇內。
13. 請勿把風扇長時間直接吹嚮老年人，小孩或病人。
14. 請勿把清潔液或殺蟲水等噴向電風扇，以免破壞塑料表層。
15. 本產品只供家庭使用。除指定用途外，切勿作其它用途使用，切勿於戶外使用本產品或作商業或工業用途。
16. 在沒有監管人監管或指導，不得讓殘疾人或弱智的人(包括小孩)使用本機。
17. 大人應監管小孩子不要玩耍本機。
18. 在任何維修和清潔前，請切斷電源。

19. 如電綫受損，必須由分銷商、代理或具認可資格的人士進行維修，以免發生危險。
20. 在移除風扇的網罩前，請先確保風扇並沒有連接上主電源。
21. 只適用於 220-240V AC,50-60Hz 的額定電壓及頻率。
22. 請勿在具有爆炸性或易燃性的物質附近使用本機。
23. 請勿將風扇或任何零件放在明火、煮食或其他會發熱的家電附近。
24. 請勿將本機掛於或安裝在牆身或天花板上。
25. 如風扇的外殼出現破損，請勿使用本機。

### 結構簡圖

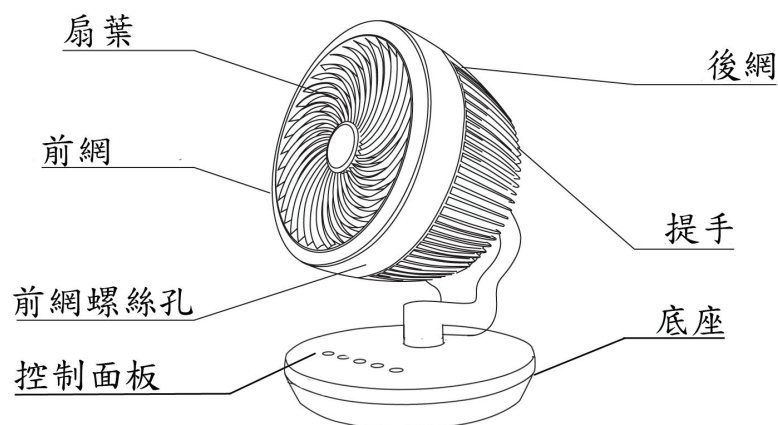

### 使用說明

1. 請確保產品是插在 220~240V~,50-60Hz 的電源上使用。
2. 連接電源後，會先聽到“Bi, Bi”的聲響，然後按下“開關鍵”，風扇開始運作。
3. 風速鍵：

本產品設有八段風速，每亮起一顆 LED 燈代表一段風速。你可按 “” 鍵來調節風速，當你選擇一档風速時，相應的指示燈會累計亮起，例如：當你選擇第一檔時，一顆 LED 燈會亮起；當你選擇第二檔時，兩顆 LED 燈會亮起...



#### 4. 模式鍵：

按“”，你可選擇正常風、自然風及睡眠風。  
當你選擇自然風及睡眠風時，相應的指示燈亮起。

#### 5. 定時鍵：(每次重新啟動時，都要重新設定)

產品可設置最高累計為 7 小時的定時，即 1 小時-2 小時-3 小時-4 小時-5 小時-6 小時-7 小時-0-1 小時....如此累推.....

#### 6. 兒童鎖：

長按“開關鍵”3 秒，可啟動“兒童鎖”，“開關鍵”的電源顯示燈會變成紅色，在這情況下，只有“兒童鎖”功能運作，其他按鍵不能操作；再長按開關鍵，可解除“兒童鎖”。

#### 7. 擺頭鍵：

(1) 按“”鍵，產品會自動左右擺頭，再按一次的話，便會停止此功能。

(2) 按“”鍵，產品會自動上下擺頭，再按一次的話，便會停止此功能。

8. 以最後一次操作計時後 15 秒，如沒有繼續操作，產品所有電源顯示燈亮度減半。

9. 如長時間不使用本機，請將電源插頭從電源插座上拔除。

### 清潔及維護

- 在清洗電風扇前，請將電源插頭拔出。
- 可使用溫和清潔液及柔軟抹布清洗扇葉、前網及後網，清洗後抹乾。
- 要清潔後網蓋，建議使用管狀的清潔器、除塵棒或吸塵機等去清除塵埃。
- 請物將風扇直接放進水中，也不可讓水滴進馬達外殼內。
- 請勿使用帶腐蝕性之清潔液，汽油及酒精等清潔塑料部份，以免變形或受損。
- 如需貯存此風扇，請放入紙箱內，並放在乾爽及空氣流通之地方。

## 技術參數

額定電壓：	220-240V~
額定頻率：	50-60 Hz
功率：	35W
產品尺寸：	260x270x358 毫米

## Product Warranty

The Warranty Card is not provided in the product packaging. You can register the product warranty online at our website <https://www.europace.com.sg/ewarranty/> within 7 (seven) days from the date of purchase. You will enjoy an additional 3 months of the product standard warranty when you register online. Please produce your E-warranty registration when requesting for repair and service at our Service Centres nearest to you.

In the event, if you are unable to register the product warranty online you must produce your purchase receipt/tax invoice and such other documentary proof of purchase of the appliance when requesting for repair and service.

### Product Warranty Coverage

You may find out your product warranty coverage at the link below before calling our Customer Service Hotline (65) 6457 3678 or visiting our Service Centre.

[http://europace.com.sg/ewarranty/src/cupload/settings\\_pdf/1/1-1-2c899-1563960978-WARRANTY-COVERAGE-19\\_0221.pdf](http://europace.com.sg/ewarranty/src/cupload/settings_pdf/1/1-1-2c899-1563960978-WARRANTY-COVERAGE-19_0221.pdf)

## **TERMS & CONDITIONS OF WARRANTY (THIS WARRANTY IS VALID IN SINGAPORE ONLY)**

Your appliance is warranted against faulty design, workmanship or materials for a period of 12 months unless otherwise stated from the date of purchase, subject to the following terms & conditions herein below:-

- 1) That the owner shall register the product warranty online at our website [www.europace.com.sg](http://www.europace.com.sg) within 7 (seven) days from the date of purchase.
- 2) That the appliance shall be used solely for domestic purposes and not for commercial purposes or any other purposes whatsoever and used strictly under the instruction for operation as provided by the manufacturers or the appliance.
- 3) That if any time during the warranty period any part or parts of this appliance is removed, tampered, modified, adjusted, altered, handled or repaired in any way whatsoever by any persons other than those authorized by Strategic Marketing (S) Pte Ltd, this warranty shall immediately cease to be valid and become void.
- 4) That the owner shall produce the E-warranty registration or tax invoice/receipt and such other documentary proof of purchase of the appliance to our satisfaction as we may deem necessary when requesting for repair and service.
- 5) That our decision on all queries relating to complaints as to defects either of workmanship or of materials shall be conclusive and the owner shall agree to abide by such a decision. Any appliance or defective part which has been replaced shall become our property.
- 6) The terms and conditions of this warranty shall be contained exclusively in this document and no other presentation of provision, either written or otherwise, regardless of the origin of the same, shall be accepted as either adding or removing from these terms and conditions.
- 7) That this warranty shall cease to be valid and void if the appliance is exported or relocated from Singapore.
- 8) That there shall be no removal, alteration, defacement, or made illegible/tampered or any kind of the serial number on the appliance.
- 9) That the owner shall be fully responsible for the due delivery and collection of the appliance for any work done according to this warranty. Transportation expenses incurred for delivery or handling the appliance are chargeable to the owner.
- 10) Transportation and labour charges apply after the full parts warranty expires. Refer to <https://www.europace.com.sg/ewarranty/> for more information.

In addition to the above, this warranty shall be subjected to the following limitations and exclusions:-

a) The appliance shall be warranted by STRATEGIC MARKETING (S) PTE. LTD. from date of purchase only for a period of:-

10 years - Heating Element warranty applies to selected models of Storage Water Heaters.

- Tank Leakage warranty applies to selected models of Storage Water Heaters.

8 years - Motor warranty applies only to selected models of Stand Fans (Walk-in warranty).

10 years - Compressor warranty applies to selected models of Refrigerators.

6 years - Motor warranty applies only to selected models of Stand Fans (Walk-in warranty).

- Compressor warranty applies only to selected models of System Air Conditioners and Portable Air Conditioners.

5 years - Compressor warranty applies to Refrigerators, Freezers, Wine Coolers, Portable Air Conditioners & Casement Air Conditioners (Outdoor warranty). Transportation is chargeable from the 2nd year to 5th year.

- Compressor warranty applies to Dehumidifiers (Walk-in warranty)

- Motor warranty applies only to selected models of Stand Fans (Walk-in warranty).

3 years - Full parts warranty applies only to selected models of Air Purifiers & selected models of Dehumidifiers (Walk-in warranty).

- Heating Element warranty applies only to selected models of Garment Steamers (Walk-in warranty).

- Motor warranty applies only to selected models of Jet Turbine Fans & selected models of Air Coolers (Walk-in warranty).

2 years - Motor and internal parts warranty applies only to selected models of Stand Fans, selected models of Oscillation Power Fans & selected models of Air Purifiers (Walk-in warranty).

- Heating Element warranty applies to selected models of Electric Ovens & selected models of Kettle Jugs. (Walk-in warranty)

- Motor warranty applies only to selected models of Jet Turbine Fans (Walk-in warranty).

- Full parts warranty applies only to Wine Coolers of 34 Bottles & above.

1 year - Full parts warranty applies to \*Lifestyle Products (cash & carry items), Small Kitchen Appliances, Fans, Air Coolers, Wine Coolers of 20 Bottles & below, Mini Bar Fridge (Walk-in warranty)

- Full parts warranty apply to Refrigerators, Air Conditioners & Freezers (Outdoor warranty).

Check out the warranty coverage of your appliance at [www.europace.com.sg](http://www.europace.com.sg)

b) The owner waives all or any claims to compensation monetary or otherwise which he/she may be entitled to and shall agree to accept any compensation whatsoever by way of additional repairs or otherwise which we in our absolute discretion may deem fit to offer. The giving of compensation shall be subjected to the other provisions of the warranty.

c) This warranty shall not be transferable, negotiable or assignable to any third party.

d) The warranty does not include transport delivery or handling charges incurred in the transportation of the appliance to and from Strategic Marketing (S) Pte Ltd.

e) Damage caused during transit where the appliance is transported for servicing, repair, or in relation thereof or connection therewith.

f) In respect of refrigerator and air conditioner only, upon the expiry of 12 months from the date of purchase, this warranty will not cover transport, refrigerant and labour to install a new compressor.

g) This warranty will not cover chemical cleaning, maintenance service, general service and overhaul, which if confirm is chargeable.

h) Defects or fault in the appliance which has been used for commercial purposes or which have been rented/leased or which have been otherwise subject to other than household use.

i) Claims for damaged/missing parts after 3 days from the original date of goods received will not be valid.

j) This warranty and the Replacement Scheme does not particularly cover damages and/or defects arising from

- Usage of wrong electrical supply/voltage.
- Usage not according to the Instruction Manual provided by the manufacturers.
- Misuse, accidents, negligence, abuse, improper installation, or any manner of tampering.
- Normal wear and tear.
- Corrosions rusting or stains.
- Scratches, dents on the unit body, casing or paintwork of the appliance.
- Act of God, fire, flood and civil unrest.
- We shall not under any obligation, legal or otherwise to repair this appliance or one to one exchange if the same shall be required as a result of losses, damages, and malfunctions arising from any of the causes mentioned in the paragraph.

k) All accessories, external parts and extruded parts such as front panel, casing, door, glass cover, glass door, cable/cord assembly, batteries, adaptor, plug, remote control, control knob, buttons, filter, UV lamp, oven tray, wooden rack, exhaust hose, fixtures, panels, cover, lid and lever, plastic parts, fan blades, blade guard, inner pots, brushes, water tanks, attachments made of glass, plastic and/or porcelain, detachable parts, and other option items are excluded from this warranty.

All services provided after the warranty period will be chargeable at standard rates determined by STRATEGIC MARKETING (S) PTE. LTD.

The terms and conditions of this warranty shall be varied except with the written and express consent or agreement of Strategic Marketing (S) Pte. Ltd. While Strategic Marketing (S) Pte. Ltd. endeavours to repair any defects after the warranty period, it is subject to availability.

It is hereby expressly provided that any liability of Strategic Marketing (S) Pte. Ltd. for any loss or damage whatsoever arising from, relating to or in connection with the purchase of the appliance shall not exceed the purchase price (excluding installation costs) of the appliance. Similarly, Strategic Marketing (S) Pte. Ltd.'s liability for any breach of this warranty shall be limited to the purchase price (excluding installation costs) of the appliance.

\* Lifestyle Products - Garment Steamer, Humidifier, Dehumidifier, Air Purifier, Mini Bar-Fridge.

\* Walk-in warranty - Customers are obliged to bring the warranted products to Strategic Marketing (S) Pte. Ltd. Service Centre for repair/service during the warranty period.



**Scan QR Code for  
the online Warranty  
Registration**

Ver. 20 \_0312



For more technical details / enquiries, please visit:

## **EUROPACE SERVICE CENTER**

**10 Changi South Street 3 #06-01 Singapore 486147**

Tel: (65) 6457 3678 | Fax: (65) 6741 0728

Operating Hours: Monday-Friday: 9am - 5pm | Saturday: 9am - 12pm

Email: [service@strategic.com.sg](mailto:service@strategic.com.sg)

[www.europace.com.sg](http://www.europace.com.sg) | [www.strategic.com.sg](http://www.strategic.com.sg)

### **RELATED PRODUCTS & MAIN CONTACT HOTLINE**

System Split Aircons | Tel: 6858 0801 | Email: [systemac@strategic.com.sg](mailto:systemac@strategic.com.sg) (Twin City)

Portable & Casement Aircons | Tel: 6291 0800 | Email: [portableac@strategic.com.sg](mailto:portableac@strategic.com.sg) (Jia Yue)

Refrigerators, Washing machines, Cookers & other major appliances |

Tel: 6289 0802 | Email: [mda@strategic.com.sg](mailto:mda@strategic.com.sg) (TnG)

*Celebrate Fine Living!*

This product is distributed by Strategic Marketing (S) Pte Ltd

If there is any technical amendment for the product, it will be edited on the updated version of the instruction manual without prior notice. The pictures shown in the instruction manual is only for illustration purpose only. If the appearance or colour of the product is modified, please refer to the actual appliance as a standard.